

mitsubishi

三菱工業用ミシン部品カタログ

Industrial Sewing Machine Parts Catalog

Model PLK-E3040

	目次	CONTENTS	Page
A	本体構成	Construction	1
B	本体関係(1)	Arm bed & it's accessories (1)	2
C	本体関係(2)	Arm bed & it's accessories (2)	4
D	縫い機構(1)	Sewing mechanism (1)	6
E	縫い機構(2)	Sewing mechanism (2)	8
F	中押え機構	Presser bar lifting mechanism	10
G	下糸切り機構	Lower thread trimming mechanism	12
H	駆動伝達機構	Drive motion mechanism	14
J	X-Yテーブル機構(1)	X-Y table mechanism (1)	16
K	X-Yテーブル機構(2)	X-Y table mechanism (2)	18
L	外押え機構	Work holder mechanism	20
M	給油機構	Oil lubrication mechanism	22
N	配線関係	Cable component	24
P	空気圧制御装置(1)	Pneumatic control unit (1)	26
Q	空気圧制御装置(2)	Pneumatic control unit (2)	28
R	テーブル関係	Table & Stand	30
S	付属品	Accessories	32
T	オプションパーツ	Option parts	34
	索引	Index	36

部品コードの採番形式

MITSUBISHI SPARE PARTS No. Designation system

1. 部品コードについて CONCERNING PARTS CODE.

部品をご注文される場合は、部品コードをお知らせください。

Please inform the part number, when these parts are ordered.

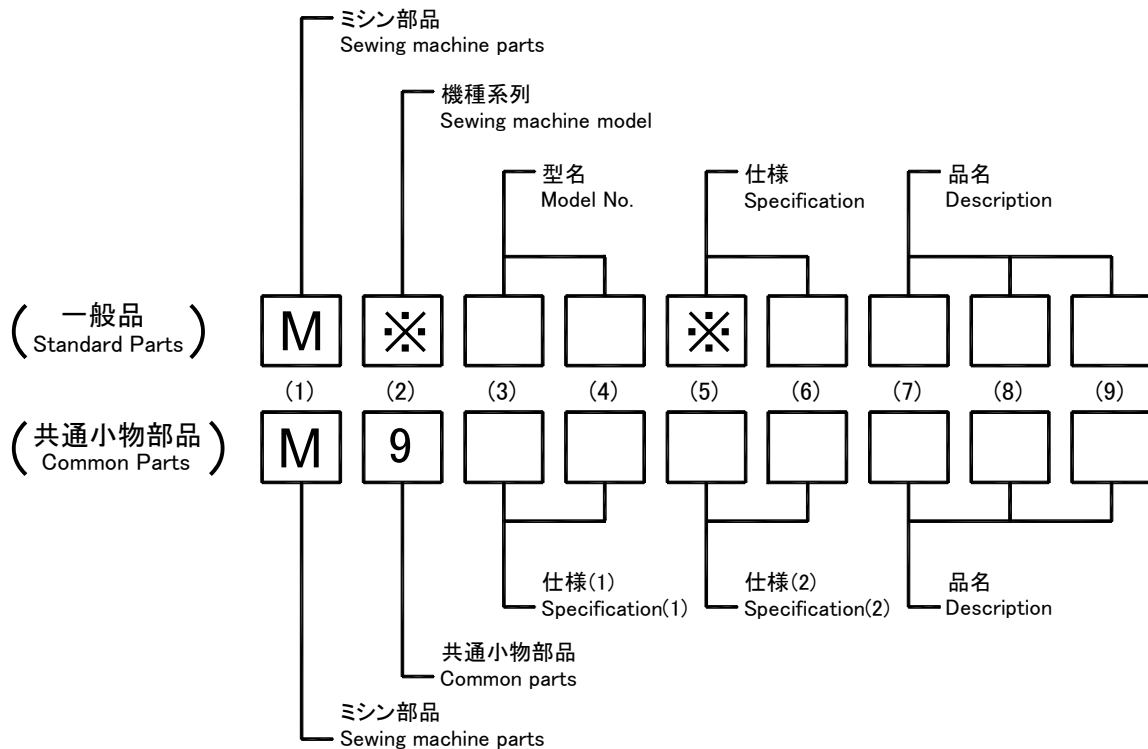

[例]
Example

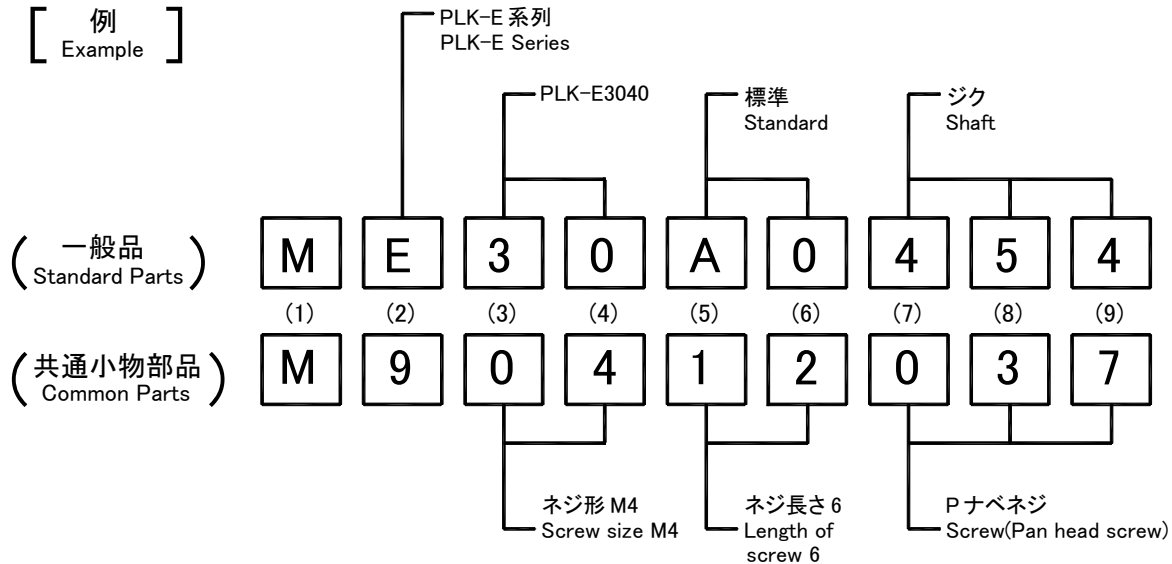

2. 変更マークについて CONCERNING MODIFICATION MARK.

変更マーク欄に * 記号のある部品は、形状、寸法などの変更履歴がありますので、ご注文の際にはご使用の製品の製造番号と合わせてご覧ください。

The parts marked with * in the modification column has been changed the shape or size etc. So when these modified parts are ordered please inform the serial number of the sewing machine.

注: 一般品についての機種型名は、その部品が最初に使用された機種型名を示します。

従って長期にわたる場合は、機種の変更が行われるため、当初の機種以外の機種で使用されている場合があります。

Sewing machine Models, of Standard Parts are Indicated model of these parts are registered firstly. Parts are used for not only the indicated model, but also another models, in reason of New development, improvement after.

A 全体構成
CONSTRUCTION

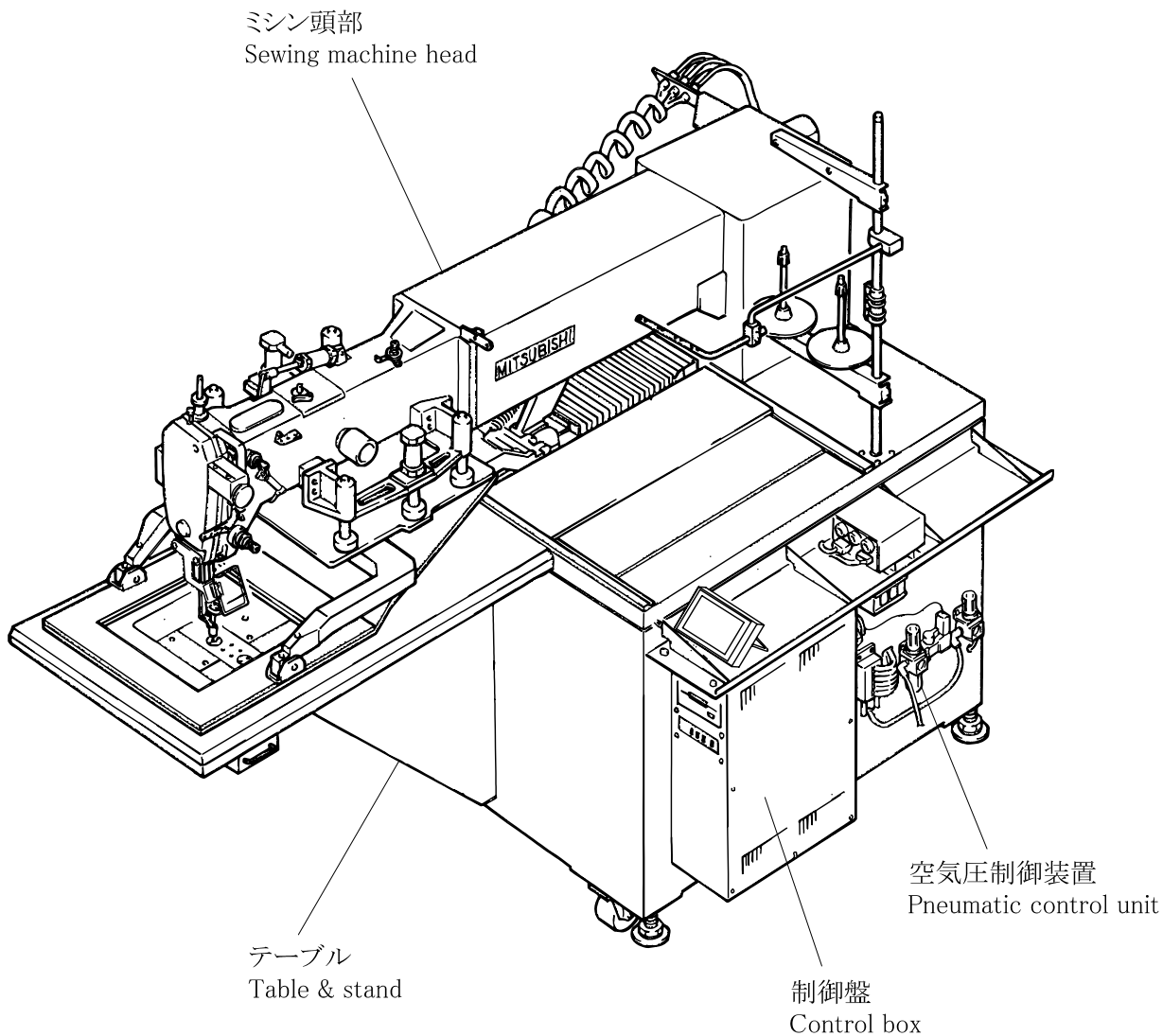

注1：モータ部分は三菱リサーボX部品カタログを参照ください。

注2：Fig.No.の採番していない部品は単体で支給することは出来ません。Setにて支給いたします。

Remarks 1) Concerning about the motor parts please refer to the parts catalog of MITSUBISHI LIMISERVO X.

Remarks 2) The parts which Fig.No are not marked are not available individually. It can be supplied with the whole component.

B 本体関係(1)
 ARM BED & IT'S ACCESSORIES(1)

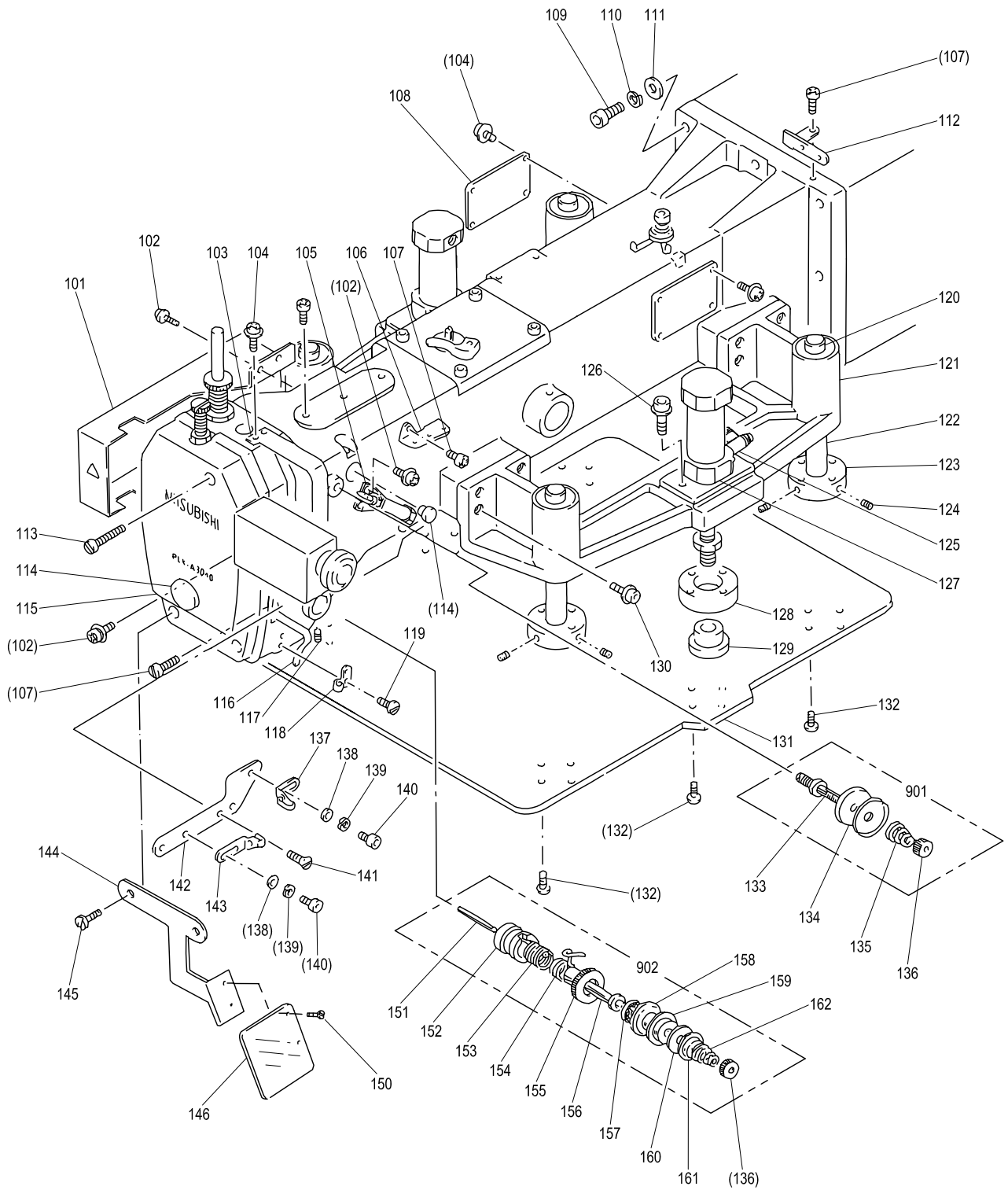

[B]本体関係(1)

ARM BED & IT'S ACCESSORIES(1)

Fig no.	変更 Mod.	部品コード Parts no.	品名	Description	数量 Amt. Req.
B 101		MB30A0339	カバー	Cover	1
B 102		M91054004	SW-PWブラマイナネジ M4X8	Screw M4X8	7
B 103		MA30A0584	テンピンカバー	Thread take-up cover	1
B 104		M91109004	サガネツキブラマイネジ 11/64(40)X9	Screw 11/64(40)X9	10
B 105		MA30A0434	エアシリンダ	Air cylinder	1
B 106		MF36A1180	イトアンナイ	Thread guide	1
B 107		M91110002	ヒラネジ 11/64(40)X8	Screw 11/64(40)X8	4
B 108		MA30A6339	カバー	Cover	2
B 109		M90105021	ロックアナツキホルト M10X35	Bolt M10X35	8
B 110		M91003053	ハネサガネ 10	Spring washer 10	8
B 111		M91012050	サガネ 10	Washer 10	8
B 112		MN80A0180	イトアンナイ	Thread guide	1
B 113		M91113002	ヒラネジ 11/64(40)X15	Screw 11/64(40)X15	3
B 114		M91910080	ゴムセン φ19	Rubber plug φ19	1
B 115		MB30A0830	メンタ	Face plate	1
B 116		MG23C0216	ウワイアンナイ	Upper thread guide	1
B 117		M91508001	ロックアナツキメネジ 15/64(28)X6	Screw 15/64(28)X6	1
B 118		MQ50A0181	イトアンナイ	Thread guide	1
B 119		M90906002	ヒラネジ 9/64(40)X4.5	Screw 9/64(40)X4.5	1
B 120		MA30A1921	リニアブッシング	Linear bushing	8
B 121		MA30A2758	ブラケット	Bracket	2
B 122		MA30A2454	ソトサエガイドシク	Guide shaft	4
B 123		MA30A4780	シャフトホルダ	Shaft holder	4
B 124		M95006020	ロックアナツキメネジ M5X12	Screw M5X12	8
B 125		MQ40A1497	スピードコントローラ	Speed controller	4
B 126		MA30A1434	エアシリンダ	Air cylinder	2
B 127		M96002017	セフティソケット M6X12	Bolt M6X12	2
B 128		MA30A0785	フローティングジョイント	Floating joint	2
B 129		MA30A0796	フローティングボス	Floting boss	2
B 130		M95004017	セフティソケット M5X16	Bolt M5X16	16
B 131		MA30A2257	オサエイタ	Presser plate	1
B 132		M95031021	ロックアナツキホタンホルト M5X12	Bolt M5X12	24
B 133		MG23C0553	チョウシホウ	Thread tension stud	1
B 134		MG23C0555	チョウシサラ	Thread tension disc	2
B 135		MG23C0245	エンスイハネ	Thread tension spring	1
B 136		M91603046	ツマミナット	Thumb nut	2
B 137		MG43A1181	イトアンナイ	Thread guide	1
B 138		M90421050	サガネ 4	Washer 4	2
B 139		M90424053	ハネサガネ 4	Spring washer 4	2
B 140		M94009021	ロックアナツキホルト M4X6	Bolt M4X6	2
B 141		M90904011	マルヒラネジ 9/64(40)X7	Screw 9/64(40)X7	2
B 142		MS06A3601	トリツケイタ	Mounting plate	1
B 143		MG43A0181	イトアンナイ	Thread guide	1
B 144		MB30A5601	トリツケイタ	Mounting plate	1
B 145		M91106003	マルヒラネジ 11/64(40)X20	Screw 11/64(40)X20	2
B 146		MB30A0160	アイガード	Eye guard	1
B 150	A	M90806002	ヒラネジ 1/8(44)X6	Screw 1/8(44)X6	2
B 151		M90208060	イトコルメピン	Releasing pin	1
B 152		MG23C1750	ブッシュ	Thread tension regulator bushing	1
B 153		MG23C0557	ネジコイルハネ	Coil spring	1
B 154		MG23C0187	イトトリハネ	Thread take-up spring	1
B 155		MG23C0750	チョウセツブッシュ	Thread tension adjusting bushing	1
B 156		MG23C1553	チョウシホウ	Thread tension stud	1
B 157		MG23C4740	フェルト	Felt	1
B 158		MG23C2555	チョウシサラ (1)	Thread tension disc (1)	1
B 159		MG23C1555	チョウシサラ (2)	Thread tension disc (2)	1
B 160		M95011050	サガネ	Tension washer	1
B 161		MG23C0556	サラオサエ	Thread tension releasing disc	1
B 162		MG23C1557	イトチョウシハネ	Thread tension spring	1
B 901		MG23C1210	チョウセツキクミタテ	Thread tension regulator assy.	1
B 902		MG23C0210	チョウセツキクミタテ	Thread tension regulator assy.	1

C 本体関係(2)
ARM BED & IT'S ACCESSORIES(2)

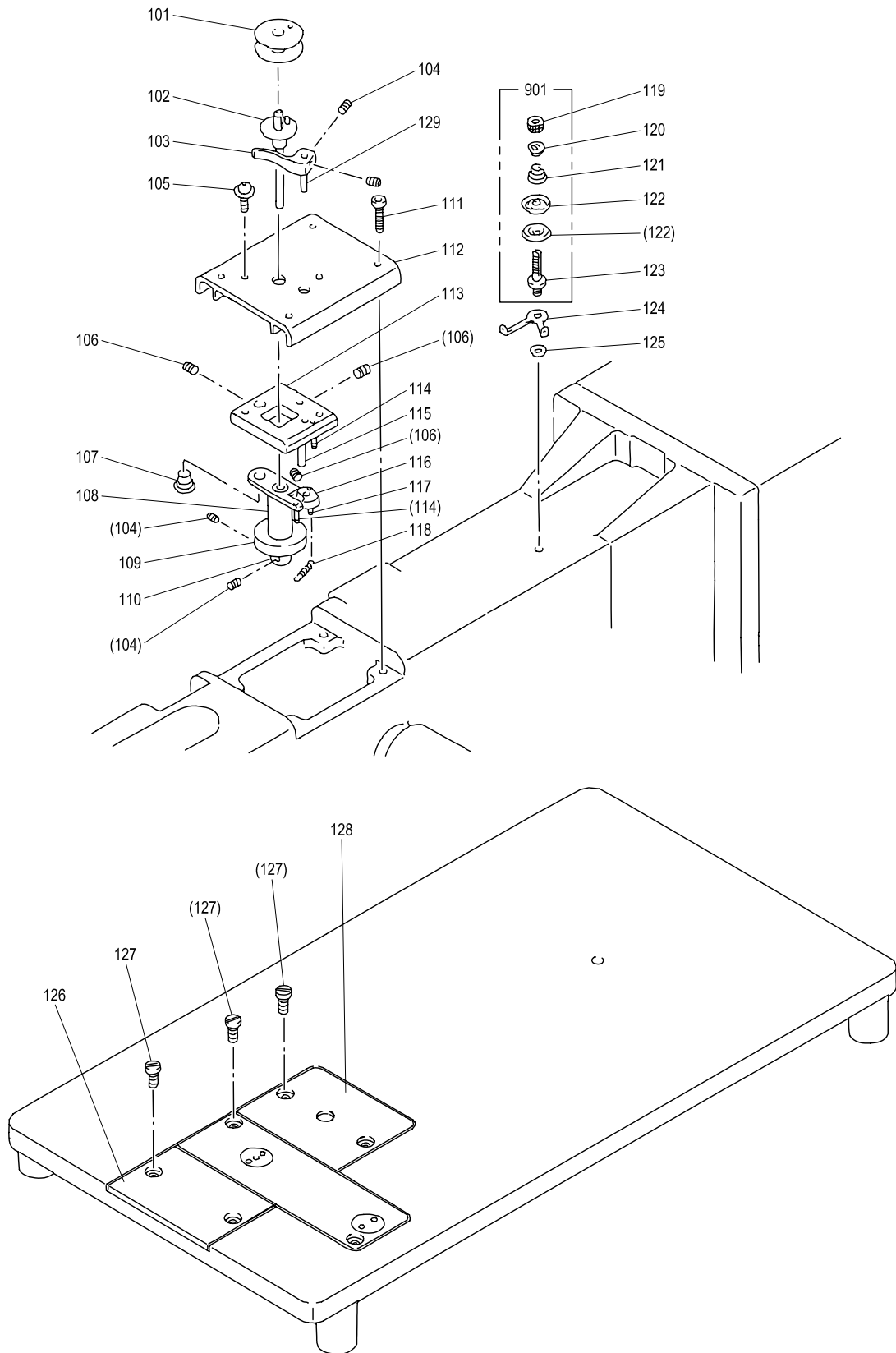

[C]本体関係(2)

ARM BED & IT'S ACCESSORIES(2)

Fig no.	変更 Mod.	部品コード Parts no.	部品名	Description	数量 Amt. Req.
C 101		MG23C0123	ホピン	Bobbin	1
C 102		MA30E1191	イマキジク	Shaft	1
C 103		MA20A1950	レバー	Lever	1
C 104		M91057020	ロッカアナツキメネジ M3X4	Screw M3X4	4
C 105	A	M91013004	SW-MWプラマイナネジ M4X8	Screw M4X8	2
C 106		M91055020	ロッカアナツキメネジ M4X4	Screw M4X4	3
C 107	A	M99006063	ツバツキジク	Pin	1
C 108		MA30E0750	ブッシュクミタテ	Bushing assy.	1
C 109		MS03A0417	ゴムワ	Tire	1
C 110		MA20A0194	イマキグルマ	Wheel	1
C 111		M94010017	セフティソケット M4X25	Bolt M4X25	4
C 112		MA30A0600	トップカバー	Top cover	1
C 113		MA30A2603	トリツケタイ	Bracket	1
C 114		M91005067	ミヅツキピン BXガタ φ2.5X12	Pin φ2.5X12	2
C 115		MS14A1454	ジク	Shaft	1
C 116		MA30A0350	カム	Cam	1
C 117		M91004067	ミヅツキピン BXガタ φ2.5X8	Pin φ2.5X8	1
C 118		MS14A0572	ツルマキハネ	Spring	1
C 119		M91602046	ツマミナット	Thumd nut	1
C 120		MM11A0702	ハネアンナイ	Spring guide	1
C 121		MM11A0245	エンスイハネ	Thread tension spring	1
C 122		MF10A0555	チョウシザラ	Thread tension disc	2
C 123		MS14A0553	チョウシホウ	Thread tension stud	1
C 124		MS14A1180	イアンナイ	Thread guide	1
C 125		MG75A1476	カラー	Collar	1
C 126		MS06A0473	スベリイタ (ヒダリ)	Slide plate (left)	1
C 127		M91207002	ヒラネジ 3/16(28)X8	Screw 3/16(28)X8	6
C 128		MA30A0474	スベリイタ (ミキ)	Slide plate (right)	1
C 129	A	MA30A2530	ダンツキジク	Shaft	1
C 901		MS14E0180	チョウセツキクミタテ	Sub thread tension regulator assy.	1

D 縫い機構(1)
SEWING MECHANISM(1)

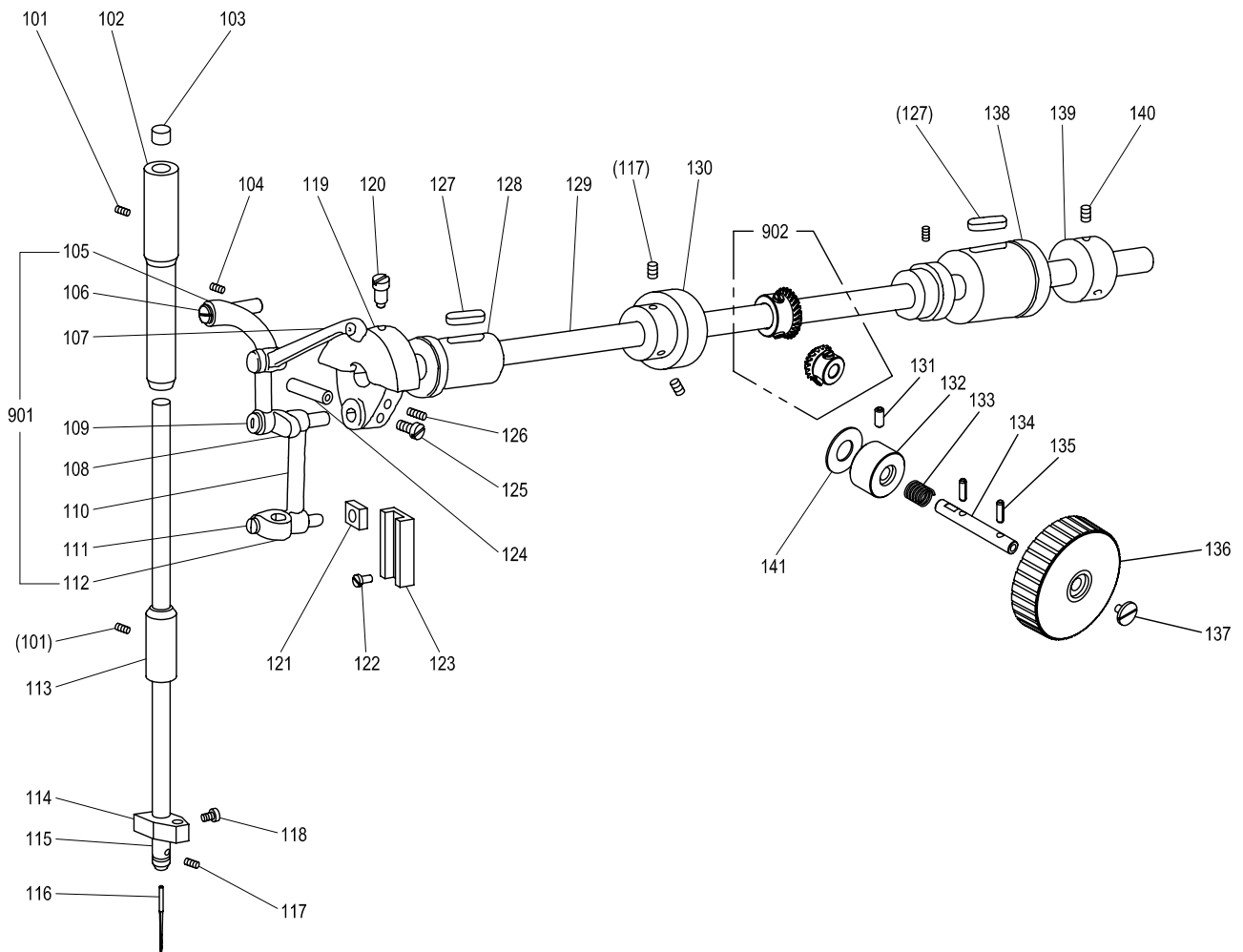

[D]縫い機構(1)

SEWING MECHANISM(1)

Fig no.	変更 Mod.	部品コード Parts no.	品名	Description	数量 Amt. Req.
D 101		M91108001	トメネジ 11/64(40)X4	Screw 11/64(40)X4	2
D 102		MG23C1663	ハリボウメタル(ウエ)	Needle bar bushing (upper)	1
D 103		MP40A3740	フェルト	Felt	1
D 104		M91517001	トメネジ 15/64(28)X18	Screw 15/64(28)X18	1
D 105		MG23E1582	テンピン	Thread take-up lever	1
D 106		MG23C0587	テンピンサエジク	Thread take-up lever hinge pin	1
D 107		M90601002	ヒラネジ 3/32(52)X6	Screw 3/32(52)X6	1
D 108		MG23C0585	テンピンクランク	Thread take-up lever crank	1
D 109		M91181003	マルヒラネジ 11/64(40)X13.5	Screw 11/64(40)X13.5	1
D 110		MG23C0661	ハリボウクランクロッド	Needle bar connecting link	1
D 111		M91251002	ヒラネジ 3/16(32)X12	Screw 3/16(32)X12	1
D 112		MG23C0665	ハリボウダキ	Needle bar holder	1
D 113		MA30A0664	ハリボウメタル(シタ)	Needle bar bushing (lower)	1
D 114		MA30A1180	イトアンナイ	Thread guide	1
D 115		MA30A0660	ハリボウ	Needle bar	1
D 116		MG23C0128	ハリ DDX1#25	Needle DDX1#25	1
D 117		M91050020	ロツカクアナツキトメネジ M4X5	Screw M4X5	3
D 118		M91515002	ヒラネジ 15/64(28)X10	Screw 15/64(28)X10	1
D 119		MG23C0383	クランク	Crank	1
D 120		M91802006	ハリサキヒラネジ 9/32(28)X14	Screw 9/32(28)X14	1
D 121		MG23C0325	カクコマ	Needle bar connecting block	1
D 122		M91110002	ヒラネジ 11/64(40)X8	Screw 11/64(40)X8	2
D 123		MG23C0662	ハリボウクランクガイド	Needle bar connecting link guide	1
D 124		M90511063	トクシュジク	Thread take-up lever crank set pin	1
D 125		M91210002	ヒラネジ 3/16(28)X10	Screw 3/16(28)X10	1
D 126		M92001001	トメネジ 5/16(28)X8	Screw 5/16(28)X8	1
D 127		MP00B0740	フェルト	Felt	2
D 128		MG23C0232	ウワジクメタル(ヒタリ)	Arm shaft bushing (left)	1
D 129		MA30A0230	ウワジク	Arm shaft	1
D 130		MA30A0682	プーリ	Pulley	1
D 131		M95006020	ロツカクアナツキトメネジ M5X12	Screw M5X12	1
D 132	A	ME25A1833	メタル	Bushing	1
D 133		MA35A2572	ツルマキハネ	Spring	1
D 134		ME30A0454	ジク	Shaft	1
D 135		M90406064	スプリングピン φ4X14	Pin φ4X14	2
D 136		ME25A0682	テマワシプーリ	Hand pulley	1
D 137		M91119002	ヒラネジ M4X8	Screw M4X8	1
D 138	A	MG23C1233	ウワジクメタル(ミキ)	Arm shaft bushing (right)	1
D 139		MA30A1352	カラー	Collar	1
D 140		M91506001	トメネジ 15/64(28)X7	Screw 15/64(28)X7	2
D 141	A	ME25A0416	カンショウゴム	Rubber	1
D 901		MG23E0582	テンピンクミタテ	Thread take-up lever assy.	1
D 902		ME30E0331	カサハグルマクミタテ	Bevel gear assy.	1

E
 縫い機構(2)
 SEWING MECHANISM(2)

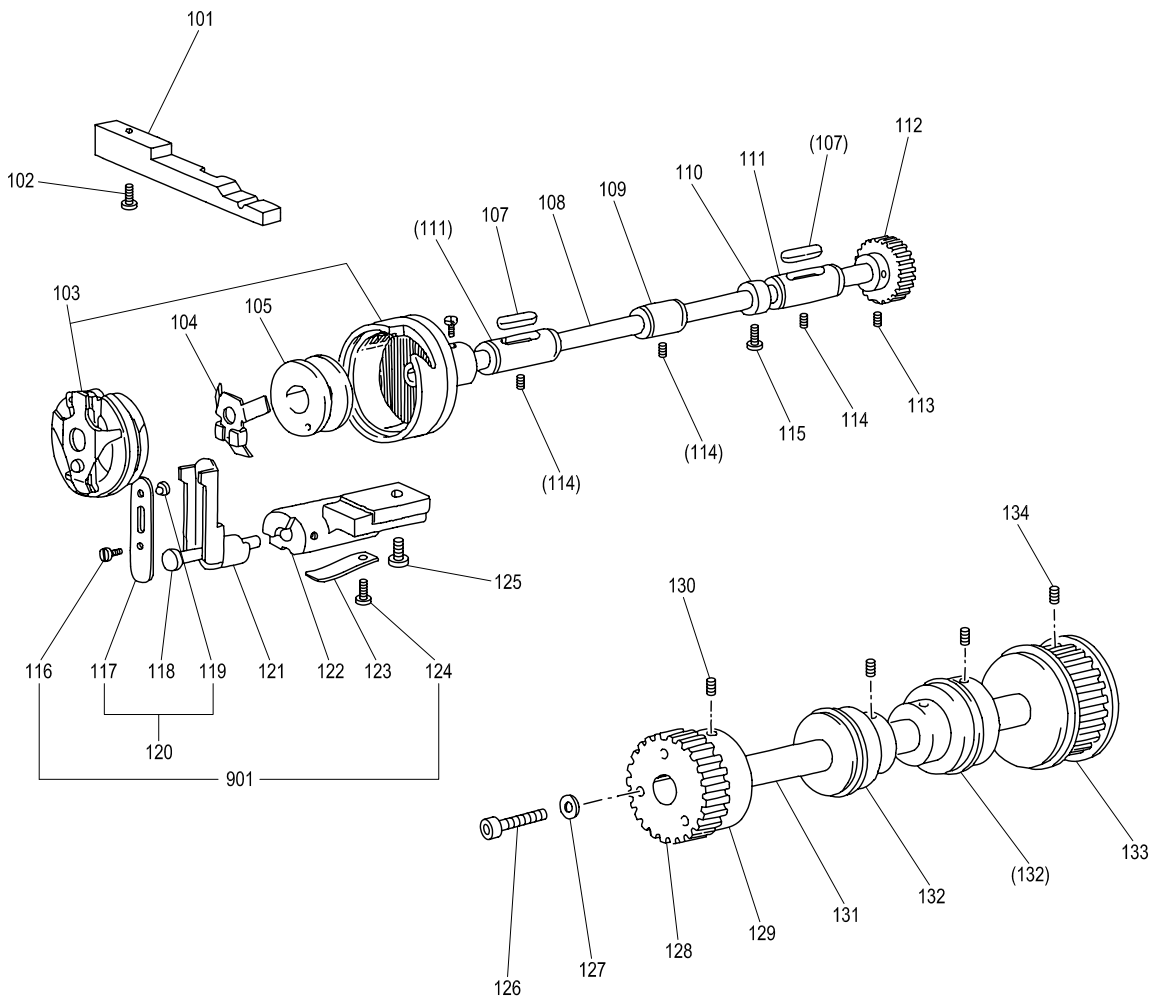

[E]縫い機構(2)

SEWING MECHANISM(2)

Fig no.	変更 Mod.	部品コード Parts no.	品 名	Description	数量 Amt. Req.
E 101		MS06A0229	ウチガトメ	Rotating hool positioner	1
E 102		M91203002	ヒラネジ 3/16(28)X15	Screw 3/16(28)X15	1
E 103		MS06E1120	カマミタ	Rotating hook assy.	1
E 104		MS06A0192	イタハネ	Plate spring	1
E 105		MG23C0123	ホビン	Bobbin	1
E 107		MG23C6740	フェルト	Felt	2
E 108		MG23C0450	シタジク	Hook shaft	1
E 109		MG23C1453	シタジクメタル (ナカ)	Hook shaft bushing (middle)	1
E 110		MG23C1352	カラー	Collar	1
E 111	A	MG23C0452	シタジクメタル	Hook shaft bushing	2
E 112		MA30A1722	ヒラハグルマ	Gear	1
E 113		M96003020	ロッカクアナツキホルト M6X6	Screw M6X6	2
E 114		M91513001	トメネジ 15/64(28)X10	Screw 15/64(28)X10	3
E 115		M91602002	ヒラネジ 1/4(40)X9	Screw 1/4(40)X9	2
E 116		M90909003	マルヒラネジ 9/64(40)X6	Screw 9/64(40)X6	1
E 117		MG23C0258	オサエイタハネ	Hook positioner spring	1
E 118		M90709063	ダンツキピン	Set pin	1
E 119		M90402063	カンピン	Set pin	1
E 120		MG23E0258	オサエイタハネクミタ	Hook positioner spring assy.	1
E 121		MG23C0257	カマオサエウテ	Hook positioner crank	1
E 122		MG23C0781	カマオサエダイ	Hook positioner bracket	1
E 123		MG23C0192	イタハネ	Spring	1
E 124		M91108002	ヒラネジ 11/64(40)X7	Screw 11/64(40)X7	1
E 125		M92051003	マルヒラネジ 5/16(24)X26	Screw 5/16(24)X26	1
E 126		M96004017	セフティソケット M6X20	Bolt M6X20	3
E 127		M90632050	サガネ 6	Washer 6	3
E 128		MA30A2722	ヒラハグルマ	Spur gear	1
E 129		MA30A1750	ブッシュ	Bushing	1
E 130		M98003020	ロッカクアナツキトメネジ M8X10	Screw M8X10	2
E 131		MA30A3454	チュウカンジク	Middle shaft	1
E 132		MA30A0456	ユニットタマジクウケ	Unit bearing	2
E 133		MA30A2767	ハガタベルトグルマ	Cog pulley	1
E 134		M91650020	ロッカクアナツキトメネジ M6X8	Screw M6X8	2
E 901		MG23E0616	カマオサエクミタ	Hook positioner assy.	1

F 中押え機構
PRESSER BAR LIFTING MECHANISM

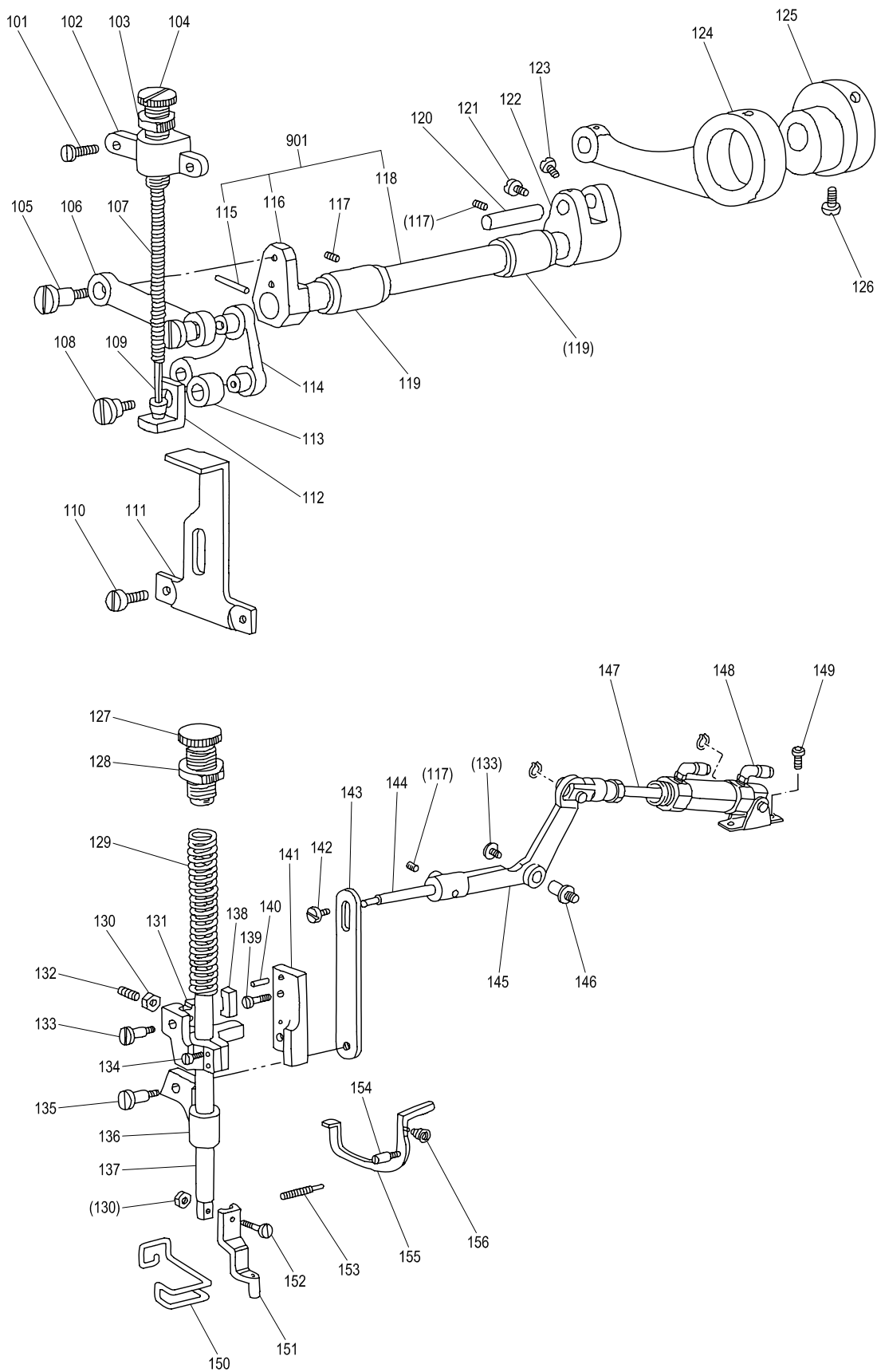

[F] 中押え機構

PRESSER BAR LIFTING MECHANISM

Fig no.	変更 Mod.	部品コード Parts no.	品名	Description	数量 Amt. Req.
F 101		M91110002	ヒラネジ 11/64(40)X8	Screw 11/64(40)X8	2
F 102		MG23C1261	オサエチョウセツダライ	Presser regulating bracket	1
F 103		M92402045	ナット 3/8(28)X5	Nut 3/8(28)X5	1
F 104		M92404035	チョウセツナット 3/8(28)X50	Thumb screw 3/8(28)X50	1
F 105		M91815015	ヒラネジダンツキ 9/32(28)X7	Hinged screw 9/32(28)X7	1
F 106		MG23C1910	リンク	Connecting link	1
F 107		MF40A0259	ツルマキハネ	Coil spring	1
F 108		M91213015	ヒラネジダンツキ 3/16(28)X14.5	Hinged screw 3/16(28)X14.5	1
F 109		MG23C1157	アンナイホウクミタテ	Guide pin	1
F 110		M91512002	ヒラネジ 15/64(28)X12	Screw 15/64(28)X12	2
F 111		MS06A0226	ウケガネ	Stopper bracket	1
F 112		MG23C0226	ウケガネ	Prop up washer	1
F 113		MS06A0352	カラー	Collar	1
F 114		MG23C0763	ベルクランク	Bell crank	1
F 115		M90401061	テーパピン φ4X23X1/50	Taper pin φ4X23X1/50	1
F 116		MS06A0276	オクリウテ (ヒダリ)	Feed lifting rock shaft crank (left)	1
F 117		M91506001	トメネジ 15/64(28)X6	Screw 15/64(28)X6	3
F 118		MS06A0460	ジョウブジョウゲシク	Presser foot lifting rock shaft	1
F 119		MG30B0285	オクリウテメタル	Rock shaft bushing	2
F 120		M90901060	ピン φ9.53X25	Set pin φ9.53X25	1
F 121		M91502002	ヒラネジ 15/64(28)X12	Screw 15/64(28)X12	2
F 122		MG23C1277	オクリウテ (ミキ)	Feed lifting rock shaft crank (right)	1
F 123		M91108002	ヒラネジ 11/64(40)X7	Screw 11/64(40)X7	1
F 124		MG23E0384	クランクロッド	Connecting rod	1
F 125		MG23C0760	ヘンシンリンク	Feed lifting eccentric	1
F 126		M91515002	ヒラネジ 15/64(28)X10	Screw 15/64(28)X10	2
F 127		M94003035	オサエチョウセツネジ 5/8(28)X49	Thumb screw 5/8(28)X49	1
F 128		M94007045	ナット 5/8(28)	Nut 5/8(28)	1
F 129		MB30A0259	オサエハネ	Presser spring	1
F 130		M91104045	ナット 11/64(40)	Nut 11/64(40)	2
F 131		MG23C0265	オサエホウダキ	Presser bar holder	1
F 132		M91111001	トメネジ 11/64(40)X10	Screw 11/64(40)X10	1
F 133		M91210002	ヒラネジ 3/16(28)X10	Screw 3/16(28)X10	2
F 134		M91203002	ヒラネジ 3/32(28)X15	Screw 3/32(28)X15	2
F 135		M91251015	ヒラネジダンツキ 3/16(32)X6	Hinged screw 3/16(32)X6	1
F 136		MG23C0475	オサエホウアケ	Presser bar lifting bracket	1
F 137		MA30A0262	オサエホウ	Presser bar	1
F 138		MG23C0751	スベリガネ	Presser bar slider	1
F 139	A	M91110002	ヒラネジ 11/64(40)X8	Screw 11/64(40)X8	2
F 140		M90304060	ピン φ3X12	Pin φ3X12	2
F 141		MG23C0263	オサエホウダキアンナイ	Presser bar holder guide	1
F 142		M91116002	ヒラネジ 11/64(40)X8	Screw 11/64(40)X8	1
F 143		MS06E0720	ソウサイタ	Presser bar lifting plate	1
F 144		M90519063	ヒキアゲシク	Pin for lifting lever	1
F 145		MA30A0725	ヒザアケレバー	Lifting lever	1
F 146		MS06A0454	ダンツキシク	Hinged shaft	1
F 147		MA30A2434	エアシリンダ	Air cylinder	1
F 148		MA30A0422	エルボユニオン	Connector	2
F 149		M98003017	セフティソケット M8X16	Bolt M8X16	2
F 150		MB50A0626	フィンガード	Finger guard	1
F 151		MA30A0256	ナカオサエ	Presser foot	1
F 152		M91113002	ヒラネジ 11/64(40)X15	Screw 11/64(40)X15	1
F 153		M91102033	ピンネジ 11/64(40)X23.5	Special screw 11/64(40)X23.5	1
F 154		M90802033	ピンネジ 9/64(40)X12	Hinged screw 9/64(40)X12	1
F 155		MS06A0220	ウワイトユルメ	Therd tension releasing lever	1
F 156		MF10A2245	インスイハネ	Spring	1
F 901		MS06E0460	ジョウブジョウゲウテクミタテ	Feed lifting rock crank assy.	1

G 下糸切り機構
LOWER THREAD TRIMMING MECHANISM

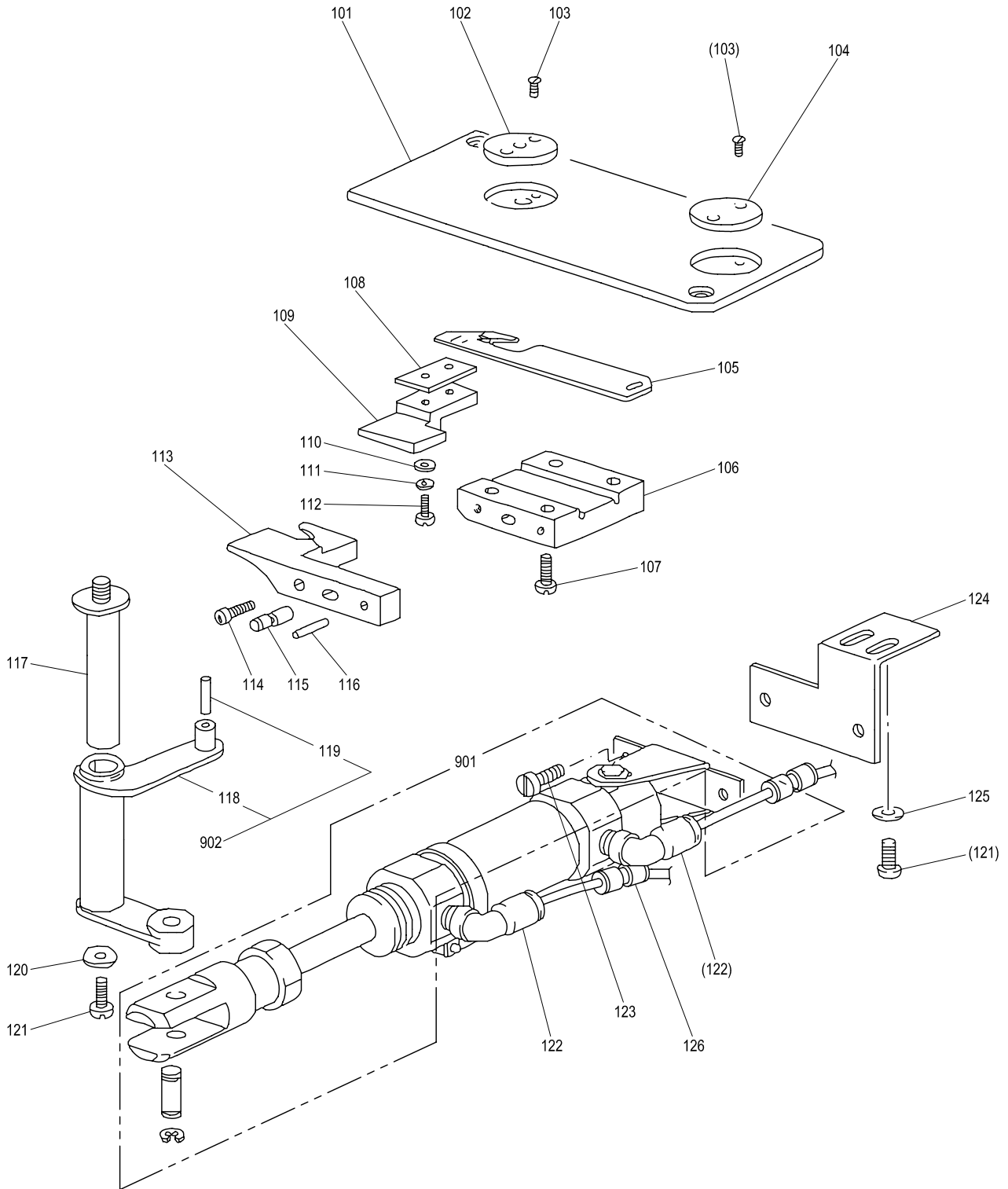

[G]下糸切り機構

LOWER THREAD TRIMMING MECHANISM

Fig no.	変更 Mod.	部品コード Parts no.	品名	Description	数量 Amt. Req.
G 101		MS06A0472	スベリイタ (ナカ).....	Slide plate (center).....	1
G 102		MS06A0101	ハリイタ (ヒダリ).....	Needle plate (left).....	1
G 103		M90605010	サラネジ 3/32(56)X2.8.....	Screw 3/32(56)X2.8.....	4
G 104		MS06A0840	メクラフタ.....	Cover.....	1
G 105		MS06B0838	イドウメス.....	Movable knife.....	1
G 106		MS06A0155	イドウメスアンナイ.....	Movable knife guide bracket.....	1
G 107		M90905002	ヒラネジ 9/64(40)X8.5.....	Screw 9/64(40)X8.5.....	4
G 108		M91503052	チョウセイサガネ 0.25t.....	Adjusting spacer 0.25t.....	1
G 108		M91504052	チョウセイサガネ 0.35t.....	Adjusting spacer 0.35t.....	1
G 109		MA70A0838	コテイメス.....	fixed knife.....	1
G 110		M90422050	サガネ 4.....	Washer 4.....	2
G 111		M90424053	ハネサガネ 4.....	Spring washer 4.....	2
G 112		M90903002	ヒラネジ 9/64(40)X6.5.....	Screw 9/64(40)X6.5.....	2
G 113		MS06A0307	メスオサエ.....	Knife fitting bracket.....	1
G 114		M91110002	ヒラネジ 11/64(40)X8.....	Screw 11/64(40)X8.....	1
G 115		M90420063	ピン.....	Eccentric pin.....	1
G 116		M90232060	ピン φ2X11.5.....	Pin φ2X11.5.....	1
G 117		MS06A0530	ダンツキシク.....	Hinged pin.....	1
G 118		MS06A0391	メスクレバ.....	Knife driving lever.....	1
G 119		M90325060	ピン φ3X13.....	Pin φ3X13.....	1
G 120		M90510050	サガネ 5.....	Washer 5.....	1
G 121		M91118002	ヒラネジ 11/64(40)X10.....	Screw 11/64(40)X10.....	3
G 122		MA30A1422	エルホユニオン.....	Connector.....	2
G 123		M91602002	ヒラネジ 1/4(40)X9.....	Screw 1/4(40)X9.....	2
G 124		MS06A0602	トリツケガネ.....	Bracket.....	1
G 125		M90421050	サガネ 4.....	Washer 4.....	2
G 126	A	ME30A1571	ツギテ (ストレート).....	Joint (street).....	2
G 901		MB30A0434	エアシリンダ.....	Air cylinder.....	1
G 902		MS06E0391	メスクレバークミタテ.....	Knife driving lever assy.....	1

H 駆動伝達機構
 DRIVE MOTION MECHANISM

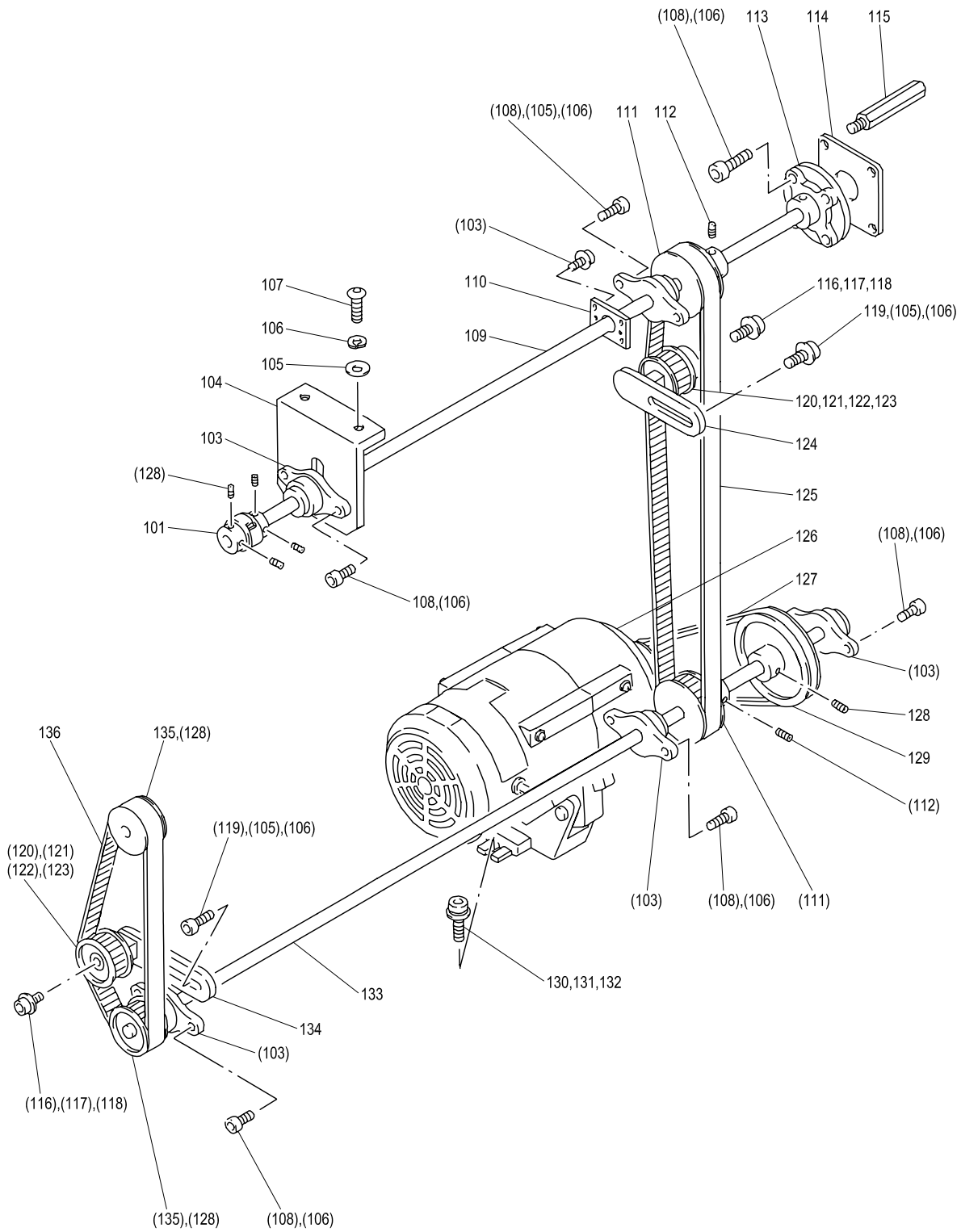

[H] 駆動伝達機構

DRIVE MOTION MECHANISM

Fig no.	変更 Mod.	部品コード Parts no.	品名	Description	数量 Amt. Req.
H 101		MA30A2364	カップリング	Coupling	1
H 103		MA30A1456	ベアリングユニット	Bearing unit	5
H 104		MA30A0426	ウワジクヨウサポート	Arm shaft support	1
H 105		M91012050	サガネ 10	Washer 10	20
H 106		M91003053	バネサガネ 10	Spring washer 10	20
H 107		M96003031	ロックアナツキホルタンボルト M10X25	Bolt M10X25	2
H 108		M90101021	ロックアナツキホルタンボルト M10X25	Bolt M10X25	18
H 109		MA30A1230	ウワジク	Arm shaft	1
H 110		MA30A1743	ウワジクヒドプレート	Bearing unit adapter	1
H 111		MA30A1682	ジョウゲシクヨウシンクローリ	Cog pulley	2
H 112		M91651020	ロックアナツキメネジ M6X16	Screw M6X16	4
H 113		MA30A2456	ベアリングユニット	Bearing unit	1
H 114		MA30A7339	ウワジクケンシュツキカバー	Arm shaft cover	1
H 115		M96004031	ケンシュツキホウコホルト	Protect detector	4
H 116		M98081021	ロックアナツキホルタンボルト M12X45	Bolt M12X45	2
H 117		M91202050	サガネ 12	Washer 12	2
H 118		M91201053	バネサガネ 12	Spring washer 12	2
H 119		M90104021	ロックアナツキホルタンボルト M10X30	Bolt M10X30	4
H 120		MA30A2682	テンションヨウシンクローリ	Cog pulley	2
H 121		MA30A3456	ベアリング	Ball bearing	4
H 122		M90332065	C型外メテ 28	C-type retaining ring 28	2
H 123		MA30A2352	テンションカラー	Tension collar	2
H 124		MA30A5780	テンションホルダー (2)	Tension holder (2)	1
H 125		MA30A3523	ハカダベルト	Cog belt	1
H 126	A	K14M97714201	Vプーリ T65	V-type pulley T65	1
H 127		MA30A0777	Vベルト M38	V-belt M38	1
H 128	A	M91650020	ロックアナツキメネジ M6X8	Screw M6X8	12
H 129		MA30A3682	Vプーリ T127	V-type pulley T127	1
H 130		M90106021	ロックホルタンボルト M10X30	Bolt M10X30	3
H 131		M91002053	バネサガネ 10	Spring washer 10	3
H 132		M93011050	サガネ	Washer	3
H 133		MA30A0450	シタジク	Hook shaft	1
H 134		MA36A6780	テンションホルダー (1)	Tension holder (1)	1
H 135		MA30A4682	シタジクシンクローリ	Cog pulley	2
H 136		MA30A4523	ハカダベルト	Cog belt	1

J X-Yテーブル機構(1)
X-Y TABLE MECHANISM(1)

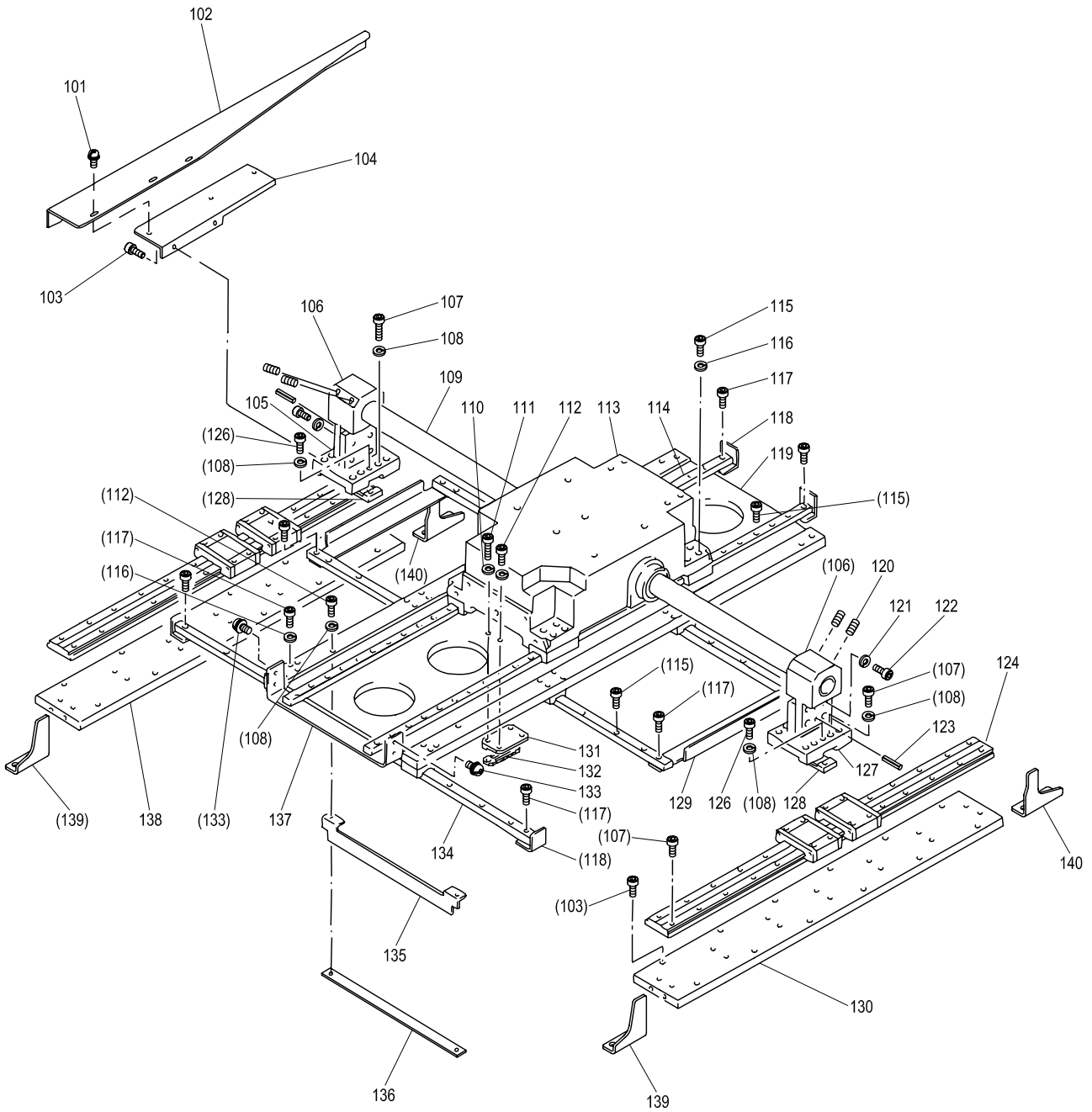

[J]X-Yテーブル機構(1)
X-Y TABLE MECHANISM(1)

Fig no.	変更 Mod.	部品コード Parts no.	品 名	Description	数量 Amt. Req.
J 101		M91071004	SW-MWプラマイナヘネジ M4X8	Screw M4X8	3
J 102		MB30A1407	Yジクケンシュツイタ	Detector plate (Y)	1
J 103		M95005017	セフティソケット M5X10	Bolt M5X10	26
J 104	A	ME30A0601	Yジクトリツケイタ	Y-Bracket	1
J 105	B	ME30A0780	ホルダー (ヒタリ)	Holder (Left)	1
J 106		MA30A0692	ハウジング	Housing	2
J 107	A	M94007017	セフティソケット M4X12	Bolt M4X12	44
J 108	A	M90422050	サガネ 4	Washer 4	22
J 109		MA30A0921	リニアフッソングクミタテ	Linear bushing assy.	1
J 110		M90421050	サガネ 4	Washer 4	4
J 111		M94010017	セフティソケット M4X25	Bolt M4X25	2
J 112		M94006017	セフティソケット M4X16	Bolt M4X16	4
J 113		MA30A0957	Yイトウレース	Y-Movable race	1
J 114		MA30A8920	Yジクリニアウェイ	Y-Linear way	2
J 115		M94005017	セフティソケット M3X10	Bolt M3X10	80
J 116		M90317050	サガネ 3	Washer 3	40
J 117		M94012017	セフティソケット M3X8	Bolt M3X8	34
J 118	A	ME30A0477	Xジクストップ (B)	X-Stopper (B)	4
J 119		MA30A1957	Xイトウレース	X-Movable race	1
J 120		M95006020	ロッカアナツキトメネジ M5X12	Screw M5X12	4
J 121		M90512050	サガネ 5	Washer 5	8
J 122		M95001017	セフティソケット M5X20	Bolt M5X20	8
J 123		M90506064	スプリングピン φ5X22	Spring pin φ5X22	4
J 124	A	ME30A0920	スライドガイド	Slide guide	2
J 126	A	M94001017	セフティソケット M4X10	Bolt M4X10	4
J 127	B	ME30A1780	ホルダー (ミキ)	Holder (Right)	1
J 128		MA35A0781	ベルトオサエ	Belt clamber	2
J 129		MA30A2477	Xジクストップ (A)	X-Stopper (A)	2
J 130		MA30A0922	リニアトリツケイタ (R)	Linear way adapter (R)	1
J 131		MB30E0476	スペーサ	Spacer	1
J 132		MA30A0778	ベルトオサエ	Belt clamber	1
J 133		M90859004	SW-PWプラマイナヘネジ M3X6	Screw M3X6	4
J 134		MA30A7920	Xジクリニアウェイ	X-Linear way	3
J 135		ME30A0407	Xジクケンシュツイタ	X-Detector plate	1
J 136		MB30A1601	トリツケイタ	Bracket	1
J 137		MA30A1477	Yジクストップ	Y-Stopper	1
J 138		MA30A1922	リニアトリツケイタ (L)	Linear way adapter (L)	1
J 139	A	ME30A1477	Yジクストップ (マエ)	Y-Stopper (front)	1
J 140	A	ME30A2477	Yジクストップ (ウシロ)	Y-Stopper (rear)	1

K X-Yテーブル機構(2)
 X-Y TABLE MECHANISM(2)

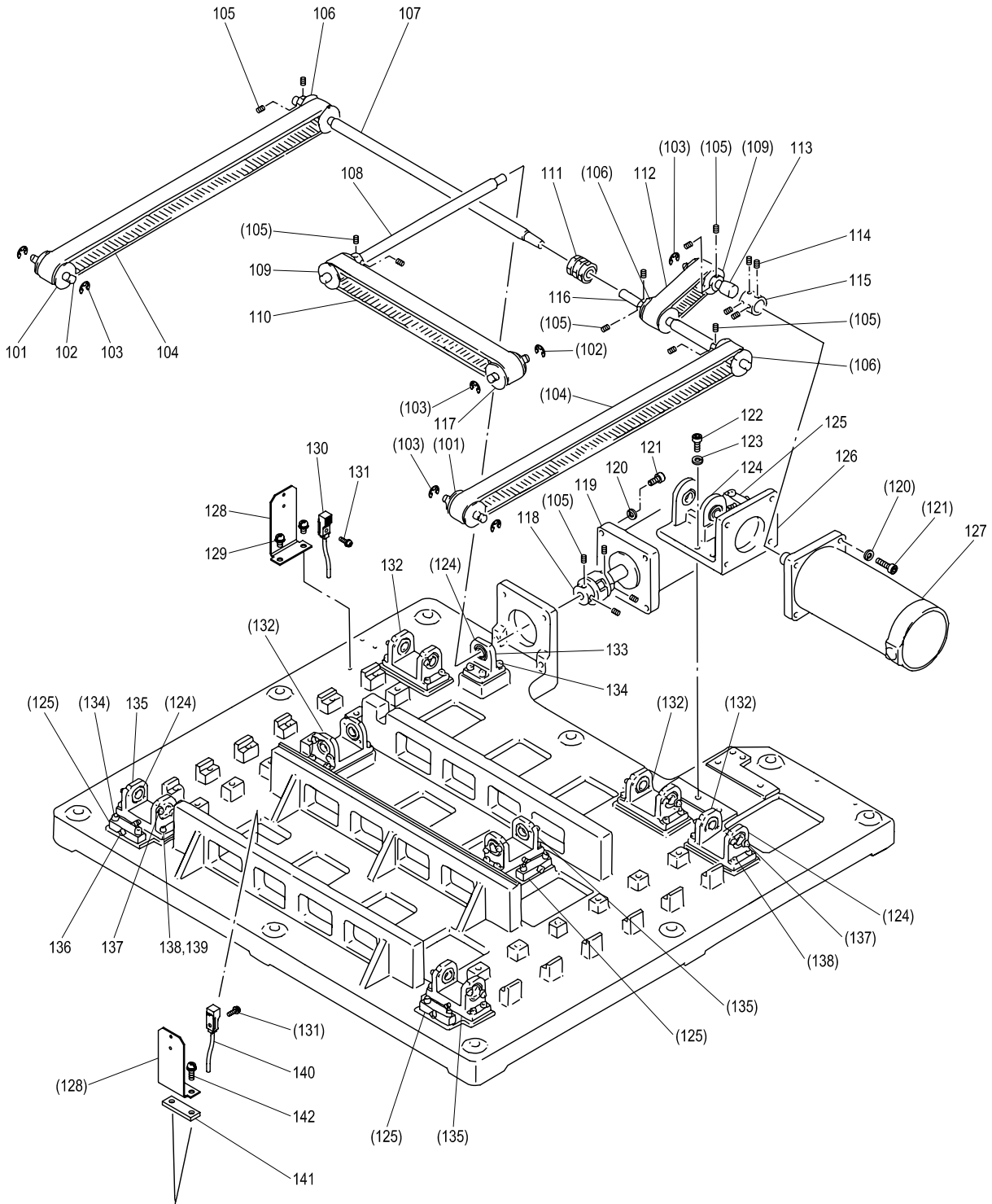

[K]X-Yテーブル機構(2)
X-Y TABLE MECHANISM(2)

Fig no.	変更 Mod.	部品コード Parts no.	品 名	Description	数量 Amt. Req.
K 101		MA30A0767	ベルトグルマ (A)	Cog pulley (A)	2
K 102		MS13A5454	ジク	Shaft	3
K 103		M90604065	Eガ外メワ 8	E-type retaining ring 8	6
K 104		MA30A0523	ハガタベルト (Y)	Cog belt (Y)	2
K 105		M96001001	ロッカクアナツキメネジ M6X8	Screw M6X8	14
K 106		MB30A0767	ベルトグルマ (B)	Cog pulley (B)	3
K 107		MA30A0454	ジク (B)	Shaft (B)	1
K 108		MB30A0390	Xク ^ト ウジク	X-Drive shaft	1
K 109		MB45A0767	ベルトグルマ (B)	Cog pulley (B)	2
K 110		MA30A2523	ハガタベルト (X)	Cog belt (X)	1
K 111		MA30A0364	カップリング	Coupling	1
K 112		MB30A0523	ハガタベルト (Y)	Cog belt (Y)	1
K 113		MB35A0390	Yク ^ト ウジク	Y-drive shaft	1
K 114		M96002001	ロッカクアナツキメネジ M6X6	Screw M6X6	4
K 115		MB30A0750	ブッシュ	Bushing	1
K 116		MA30A1454	ジク (A)	Shaft (A)	1
K 117		MB62A0767	ベルトグルマ	Cog pulley	1
K 118		MB30A0364	カップリング	Coupling	1
K 119		M95055095	ステッピングモータ (X)	Motor complete (X)	1
K 120		M90631050	ザガネ 6	Washer 6	8
K 121		M96010017	セフティソケット M6X25	Bolt M6X25	8
K 122		M95008017	セフティソケット M5X25	Bolt M5X25	4
K 123		M90511050	ザガネ 5	Washer 5	4
K 124		MS02A2456	ベアリング	Ball bearing	17
K 125		MA30A0751	テンションブロック	Tension block	4
K 126		MB30A0603	モータリツケダイ	Motor bracket	1
K 127		M95054095	ステッピングモータ (Y)	Motor complete (Y)	1
K 128	A	ME30A0408	ケンセツツダイ	Detector bracket	2
K 129	A	M91054004	SW-PW ^ラ マイナ ^ハ ネジ M4X8	Screw M4X8	2
K 130		ME30A0484	ケンセツスイッチ (Y)	Detector (Y)	1
K 131		M90971004	SW-PW ^ラ マイナ ^ハ ネジ M3X10	Screw M3X8	2
K 132		MA30A0758	ブラケット	Bracket	4
K 133		MA35A1758	ブラケット	Bracket	1
K 134		M95001017	セフティソケット M5X20	Bolt M5X20	12
K 135		MA35A6758	ブラケット	Bracket	3
K 136		M95030021	ロッカクアナツキボルト M5X30	Bolt M5X30	4
K 137		M91071004	SW-MW ^ラ マイナ ^ハ ネジ M4X8	Screw M4X8	32
K 138		M95004017	セフティソケット M5X16	Bolt M5X16	28
K 139		M90512050	ザガネ 5	Washer 5	8
K 140		ME30A1484	ケンセツスイッチ (X)	Detector (X)	1
K 141	A	ME30A0476	スペーサ	Spacer	1
K 142	A	M91073004	SW-PW ^ラ マイナ ^ハ ネジ M4X16	Screw M4X16	2

L 外押え機構
WORK HOLDER MECHANISM

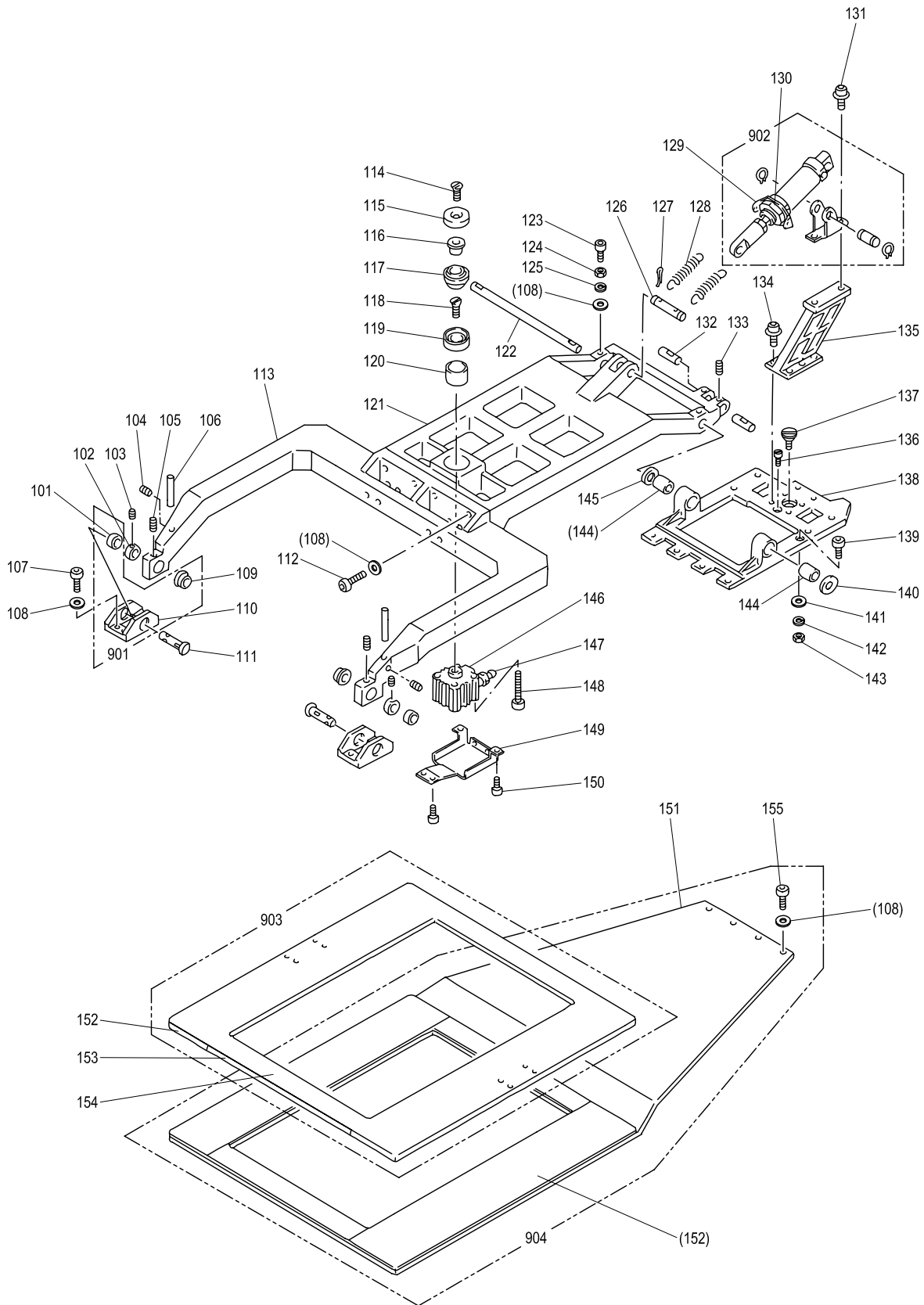

[L]外押え機構

WORK HOLDER MECHANISM

Fig no.	変更 Mod.	部品コード Parts no.	品名	Description	数量 Amt. Req.
L 101		MA30A3750	ブッシュ	Bushing	2
L 102		MA30A3352	カラー	Collar	2
L 103		M91050020	ロッカクアナツキメネジ M4X5	Screw M4X5	4
L 104		M95004021	ロッカクアナツキメネジ M5X5	Screw M5X5	2
L 105		M95016021	ロッカクアナツキメネジ M5X10	Screw M5X10	2
L 106		M97014060	ピン	Pin	2
L 107	A	M95002017	セフテイツケット M5X12	Screw M5X12	8
L 108		M90511050	サガネ 5	Washer 5	22
L 109		MA30A2750	ツハツキブッシュ	Bushing	2
L 110		MA30A6456	ジクウケダイ	Shaft supporter	2
L 111		MA30A4454	ツハツキジク	Shaft	2
L 112		M95008017	セフテイツケット M5X25	Screw M5X25	8
L 113		MA30A0273	オサエウデ (マエ)	Clamp frame (front)	1
L 114		M91500010	Pサラネジ M5X12	Screw M5X12	1
L 115		MA30A0457	シュウトウシ	Slider	1
L 116		MA30A6750	インナーブッシュ	Inner bushing	1
L 117		MA30A5456	キューメンジクウケ	Bearing	1
L 118		M98001037	Pサラネジ M8X10	Screw M8X10	1
L 119		MA30A5750	スライドブッシュ	Slide bushing	1
L 120		MA30A4750	ブッシュ	Bushing	1
L 121		MA30A1273	オサエウデ (ウシロ)	Clamp frame (rear)	1
L 122		MS05A3454	ソトオサエカイツジク	Shaft	1
L 123		M95011021	ロッカクアナツキホルト M5X25	Screw M5X25	2
L 124		M91382045	ナット M5	Nut M5	2
L 125		M90504053	ハネザガネ 5	Spring washer 5	2
L 126		M97015060	ナックルピン	Pin	1
L 127		M90108062	ワリピン	Pin	2
L 128		MA30A0700	コイルハネ	Spring	2
L 129		MA30A0708	ハネカケガネ	Spring supporter	1
L 130		M95022045	ロッカクナット M32	Nut M32	1
L 131		M98003017	セフテイツケット M8X16	Bolt M8X16	2
L 132		M90803060	ピン	Pin	2
L 133		M95001020	ロッカクアナツキメネジ M5X10	Screw M5X10	2
L 134		M95004017	セフテイツケット M5X16	Bolt M5X16	6
L 135		MA30A0483	CYLスタント	Cylinder stand	1
L 136		M98001033	ピンネジ	Pin screw	1
L 137		M98001015	ヒラネジダンツキ M8X10	Screw M8X10	1
L 138		MA30A3603	シタオサエトリツケダイ	Base	1
L 139		MS05A4454	トクシジク	Shaft	1
L 140		M93012050	スぺーサ (3.0T)	Spacsr (3.0t)	1
L 141		M90825050	サガネ 8	Washer 8	1
L 142		M90803053	ハネザガネ 8	Spring washer 8	1
L 143		M92075045	ナット M8	Nut M8	1
L 144		MS05A0750	ブッシュ	Bushing	2
L 145		M93013050	スぺーサ (3.1T)	Spacsr (3.1t)	1
L 146		MA30A4434	エアシリンダ	Air cylinder	1
L 147		MA30A0716	ハーフユニオン	Connector	1
L 148		M95008021	ロッカクアナツキホルト M5X35	Screw M5X35	4
L 149		MA30A7339	シリンダカバー	Cylinder cover	1
L 150	A	M95003017	セフテイツケット M5X8	Screw M5X8	4
L 151	A	ME30A0272	シタオサエイタ	Lower clamp plate	1
L 152		MB30E1691	パッキン	Clamp pad	2
L 153		MB30E0691	パッキン	Clamp pad	1
L 154		MA30A3257	ウワオサエイタ	Upper clamp plate	1
L 155	A	M95005017	セフテイツケット M5X10	Screw M5X10	8
L 901		MA30A4456	ジクウケダイクミタテ	Shaft supporter	2
L 902	A	ME30A0434	エアシリンダ	Air cylinder	1
L 903		MA30E0257	ウワオサエイタクミタテ	Upper clamp plate assy.	1
L 904		MA30E0272	シタオサエイタクミタテ	Lower clamp plate assy.	1

M 給油機構
OIL LUBRICATION MECHANISM

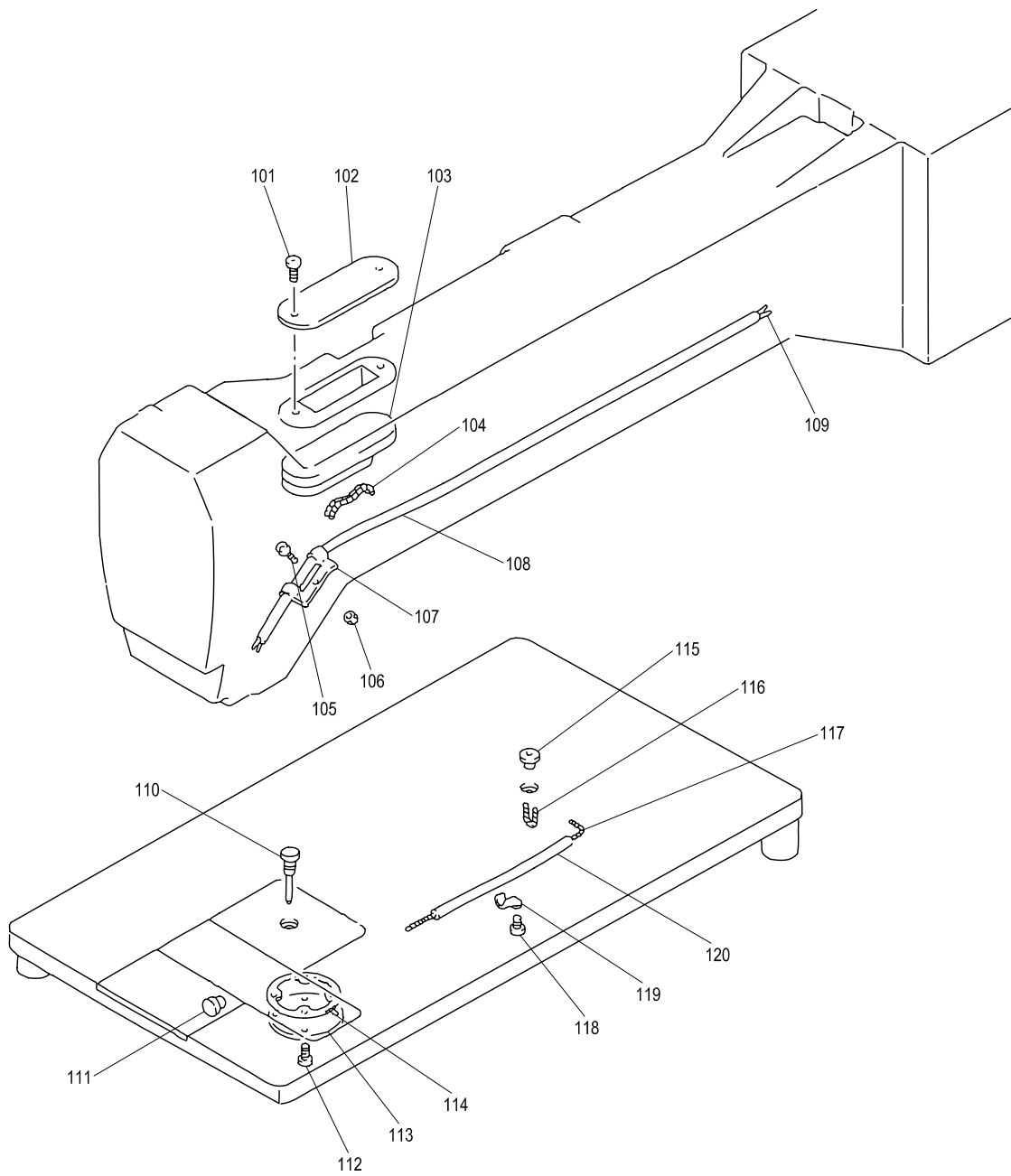

[M]給油機構

OIL LUBRICATION MECHANISM

Fig no.	変更 Mod.	部品コード Parts no.	品 名	Description	数量 Amt. Req.
M 101		M91113004	ブ ^ラ マイネジ [°] 11/64(40)X7	Screw 11/64(40)X7	2
M 102		MV11A0134	ア ^ブ ラ ^フ タ	Oil cover	1
M 103		MS06A0740	フ ^ェ ルト	Felt	2
M 104	A	MN70E0148	ア ^ブ ラ ^ヒ モ	Oil wick	1
M 105		M90918002	ヒ ^ラ ネジ [°] 6/64(40)X23	Screw 9/64(40)X23	1
M 106		M90901045	ナ ^ツ ト 9/64(40)	Nut 9/64(40)	1
M 107		MG23C0689	ハ ^イ プ [°] ホルダ [°]	Pipe holder	1
M 108		MF10A0731	ハ ^イ プ [°]	Oil pipe	1
M 109		MG23C0400	ア ^ブ ラ ^ヒ モ	Oil wick	3
M 110		MS06A0250	オ ^イ ルゲ ^ー ジ [°]	Oil gauge	1
M 111		M90740080	ゴ ^ム セ ^ン φ7.4	Rubber plug φ7.4	1
M 112		M91118002	ヒ ^ラ ネジ [°] 11/64(40)X10	Screw 11/64(40)X10	4
M 113		MN10A3742	フ ^タ	Cover	1
M 114		MN10A1691	ハ ^ッ キン	Gasket	1
M 115		MN10A4742	オ ^イ ルカ ^ッ プ	Oil cap	1
M 116		MF10E2148	ア ^ブ ラ ^ヒ モ	Oil wick	1
M 117		MN70E0148	ア ^ブ ラ ^ヒ モ	Oil wick	1
M 118		M91110002	ヒ ^ラ ネジ [°] 11/64(40)X8	Screw 11/64(40)X8	2
M 119		MF10A0689	ハ ^イ プ [°] ホルダ [°]	Oil pipe holder	2
M 120		MG23A0731	ビ ^ニ ールハ ^イ プ [°]	Oil pipe	1

N 配線関係
CABLE COMPONENT

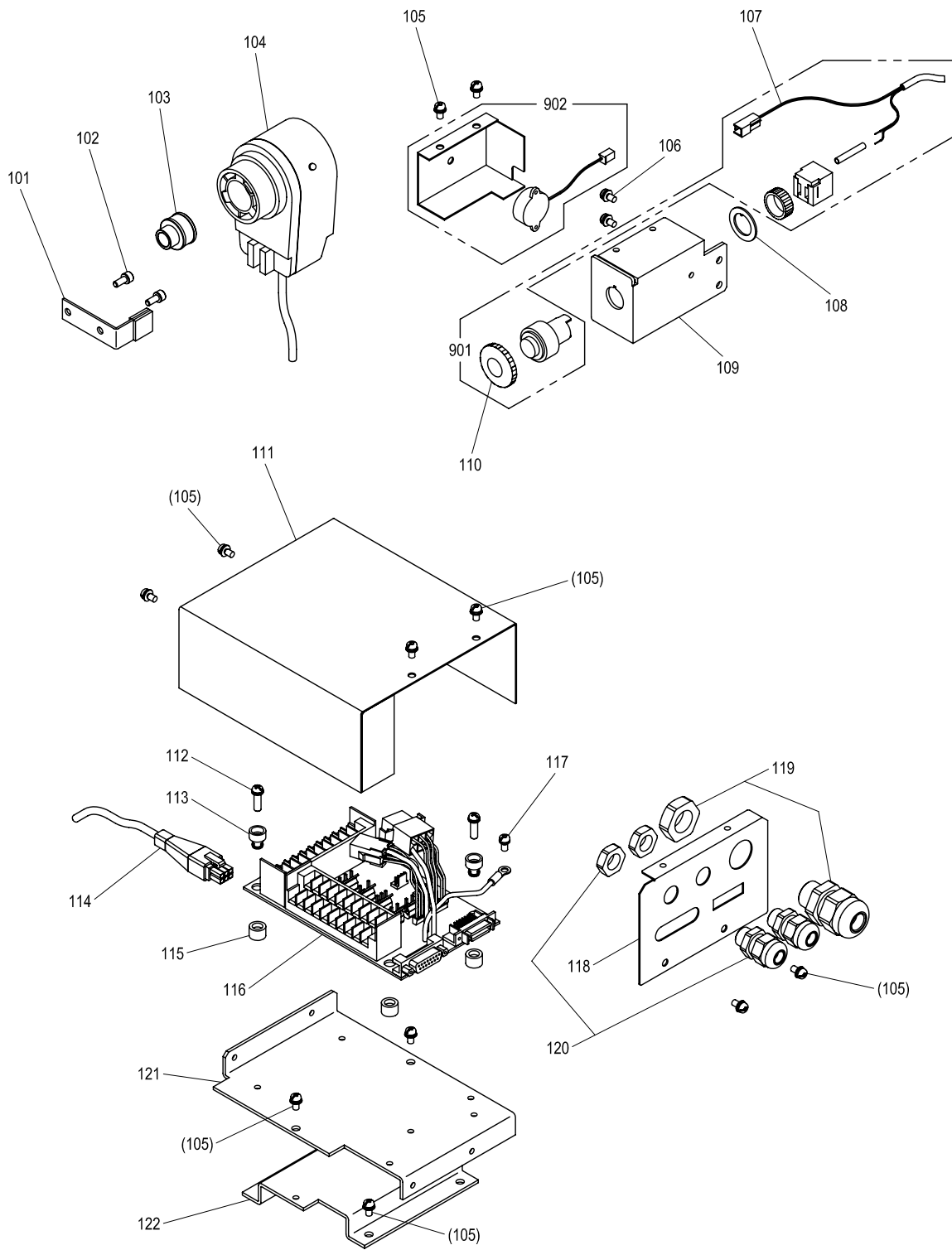

[N]配線関係

CABLE COMPONENT

Fig no.	変更 Mod.	部品コード Parts no.	品名	Description	数量 Amt. Req.
N 101		MA30E0802	マワリトメ	Stopper	1
N 102		M94001017	セフテイツケット M4X10	Bolt M4X10	2
N 103		K14M09022805	ジツギキテ	Adapter	1
N 104	A	K14MXCKE01P0	ウワジクセンシュツキ	Detector	1
N 105		M91054004	SW-PWフライナネジ M4X8	Screw M4X8	14
N 106		M91056004	SW-PWフライナネジ M4X10	Screw M4X10	2
N 107		ME30A0508	セツクテンセン	Cable (stop BZ)	1
N 108		MB60A0915	ロックリング	Lock ring	1
N 109		MB30A2601	トリツケイタ	Bracket	1
N 110		ME03A0270	プッシュボタン	Push button	1
N 111		MB50A3339	パンカバー	Circuit board cover	1
N 112		M91073004	SW-PWフライナネジ M4X16	Screw M4X16	4
N 113		MB60A0366	ワシタッチブッシュ	Nylon bush	4
N 114		K14M71725402	ケーブル (エンコーダ)	Cable (Encoder)	1
N 115		MB60A2352	ワシタッチブッシュ	Nylon bush	4
N 116	A	M800E2CON	パンクミタテ PLK-E2-CON	Print circuit board	1
N 117		M90439037	SWフライナネジ M4X8	Screw M4X8	1
N 118		MB60A5601	コネクタトリツケイタ	Connector panel	1
N 119		MB60A5780	コードブッシュ 大	Cord bushing (large)	1
N 120		MB60A6780	コードブッシュ ショウ	Cord bushing (small)	2
N 121		MB35A7601	パントリツケイタ	Circuit board bracket	1
N 122		MB30A3601	サポート	Adapter	1
N 901		ME30E0270	オシボタンスイッチ	Switch assy.	1
N 902		MB60E3339	カバー (フサツキ)	Cover assy. (with buzzer)	1

P 空気圧制御装置(1)
PNEUMATIC CONTROL UNIT(1)

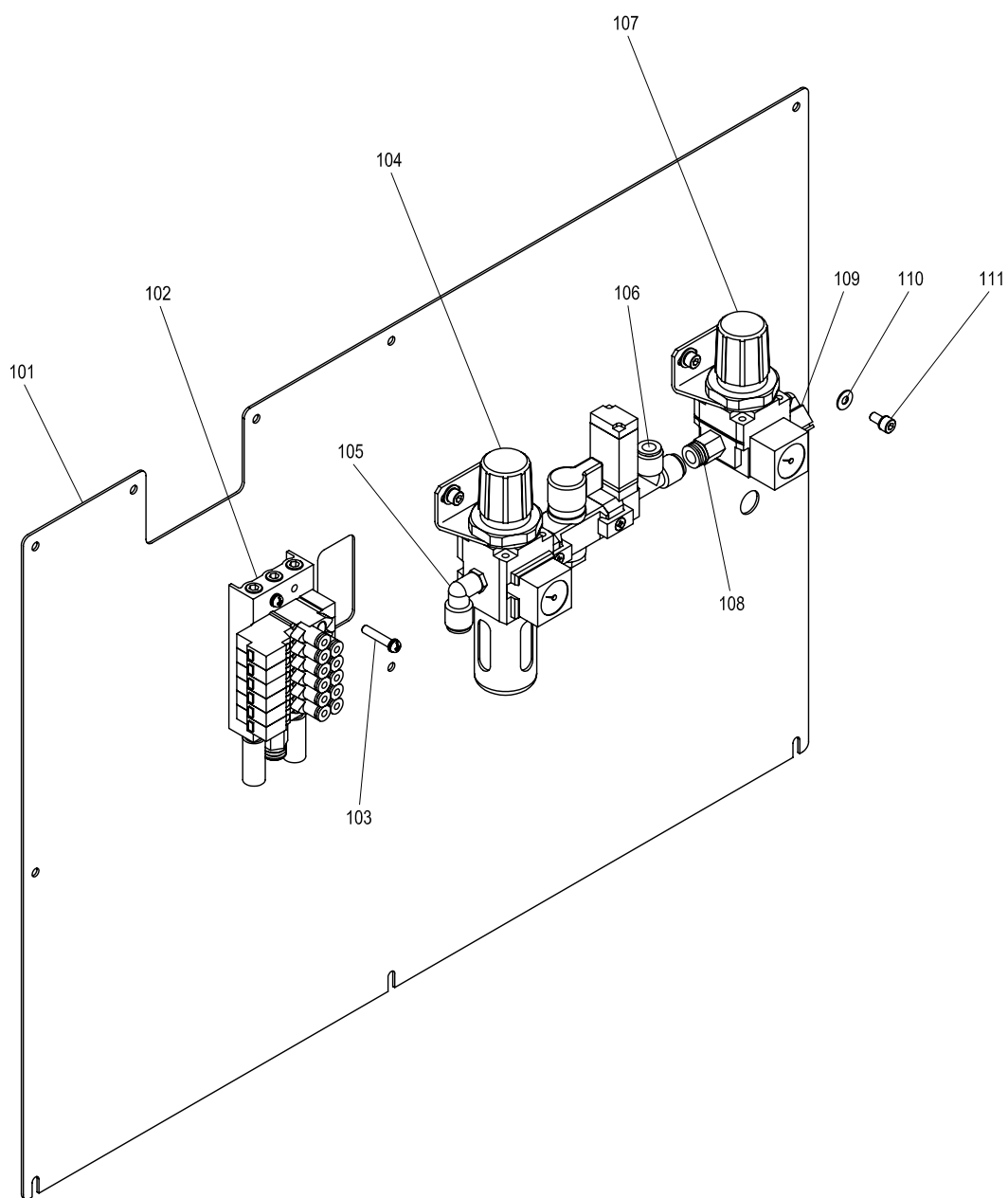

[P]空気圧制御装置(1)
PNEUMATIC CONTROL UNIT(1)

Fig no.	変更 Mod.	部品コード Parts no.	品 名	Description	数量 Amt. Req.
P 101		ME30A0339	カバー	Cover	1
P 102		MB30E0599	ソレノイドバルブ	Solenoid valve assy.	1
P 103		M91066004	SW-PWブラマイナベネジ M4X25	Screw M4X25	4
P 104		MB30E0963	フィルタレギュレータ	Filter regulator assy.	1
P 105		MA20A8571	ワンタッチツギテ	Quick joint	1
P 106		ME30A0571	チースユニオン	Quick joint	1
P 107		MB30A0963	レギュレータ	Regulator	1
P 108	A	MA20A7571	ワンタッチツギテ	Quick joint	1
P 109		MA30A0422	ワンタッチツギテ	Quick joint	1
P 110		M90511050	ワッシャー 5	Washer 5	4
P 111		M95005017	セフティソケット M5X10	Bolt M5X10	4

Q 空気圧制御装置(2)
PNEUMATIC CONTROL UNIT(2)

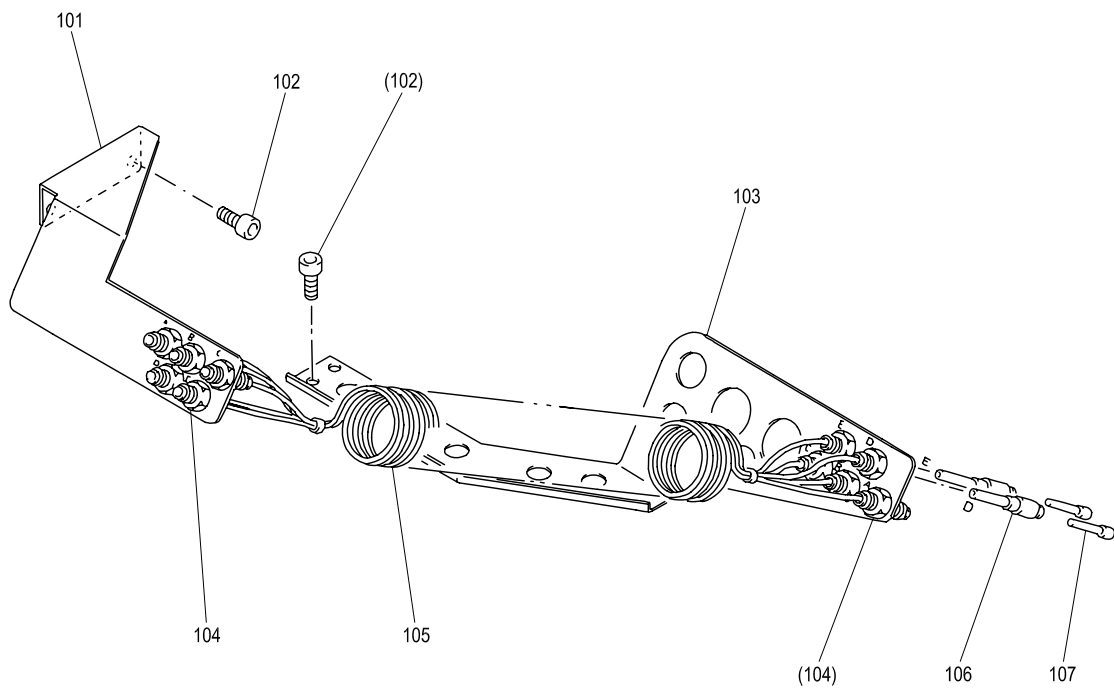

[Q]空気圧制御装置(2)

PNEUMATIC CONTROL UNIT(2)

Fig no.	変更 Mod.	部品コード Parts no.	品 名	Description	数量 Amt. Req.
Q 101		MA30A0809	マニホールド* (1).....	Manifold (1).....	1
Q 102		M95002017	セフティソケット M5X12.....	Bolt M5X12.....	6
Q 103		MA30A1809	マニホールド* (2).....	Manifold (2).....	1
Q 104		MA30A5571	ワンタッチツキテ.....	Quick joint.....	10
Q 105		MA30A1567	コイルチューブ.....	Coil tube.....	1
Q 106		MA30A0964	レジュース.....	Reducer.....	2
Q 107		MA30A0757	プラグ.....	Plug.....	2

☐ テーブル関係
TABLE & STAND

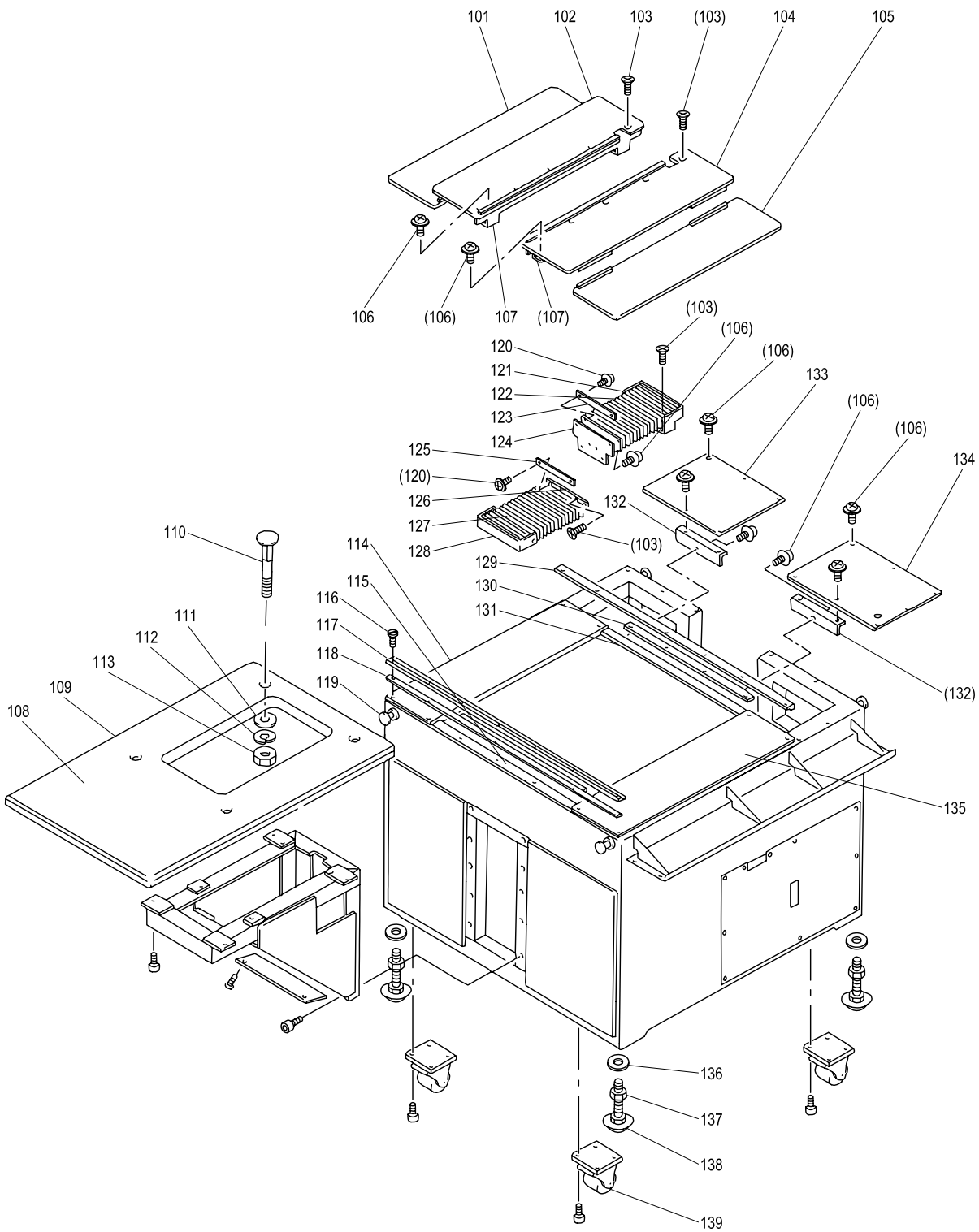

[R]テーブル関係
TABLE & STAND

Fig no.	変更 Mod.	部品コード Parts no.	品 名	Description	数量 Amt. Req.
R 101		MA30E2339	Xカバークミタテ	X-cover assy.	1
R 102		MA30E4339	Xカバークミタテ	X-cover assy.	1
R 103		M91064004	Pサラネジ M4X6	Screw M4X6	18
R 104		MA30E3339	Xカバークミタテ	X-cover assy.	1
R 105		MA30E1339	Xカバークミタテ	X-cover assy.	1
R 106		M91071004	SW-MWブラマイナヘネジ M4X8	Screw M4X8	24
R 107		MA30E0603	Xカバートリツケダイクミタテ	X-cover stand assy.	2
R 108		MA30A0797	ホコフィルム	Slide plate guard film	1
R 109		MA30A0595	テーブル	Table top	1
R 110		M98020022	トリツケホルト M8X70	Bolt M8X70	4
R 111		M90823050	ワッシャー 8	Washer 8	4
R 112		M90803053	ハネワッシャー 8	Spring washer 8	4
R 113		M92075045	ナット M8	Nut M8	4
R 114		MA30A1339	X-Yカバー (L)	X-Y cover (L)	1
R 115		MA30A0747	ブリッジ (F)	Bridge (F)	1
R 116		M91132002	ヒラネジ 11/64(40)X12	Screw 11/64(40)X12	14
R 117		MA30A0359	カバーガイド (F-UP)	Cover guide (F-UP)	1
R 118		MA30A0476	スペーサ (F)	Spacer (F)	1
R 119		MA30A0755	ツリフック	Hook	4
R 120		M91058004	SW-PWブラマイナヘネジ M3X6	Screw M3X6	12
R 121		MA30A0602	シャッターアダプタ	Shutter adapter	1
R 122		MA30A0458	シャッター (R)	Shutter (R)	1
R 123		MA30A0257	シャッターホルダ	Shutter holder	1
R 124		MA30A0780	ホルダ	Holder	1
R 125		MA30A1257	シャッターホルダ	Shutter holder	2
R 126		MA30A1780	ホルダ	Holder	1
R 127		MA30A1458	シャッター (F)	Shutter (F)	1
R 128		MA30A0601	シャッターアダプタ	Shutter adapter	1
R 129		MA30A1359	カバーガイド (R)	Cover guide	1
R 130		MA30A1476	スペーサ	Spacer	1
R 131		MA30A1747	ブリッジ (R)	Bridge (R)	1
R 132		MA30A0361	Lカタカナグ	L-bracket	2
R 133		MA30A2339	リアカバー (L)	Rear cover (L)	1
R 134		MA30A3339	リアカバー (R)	Rear cover (R)	1
R 135		MA30A0339	X-Yカバー (R)	X-Y cover (R)	1
R 136		M92002050	ワッシャー 20	Washer 20	4
R 137		M95020045	ナット M20	Nut M20	4
R 138		MA35A0166	レベルアジャスター	Adjustor	4
R 139		MB50A1972	キャスター	Castor	4

S 付属品
ACCESSORIES

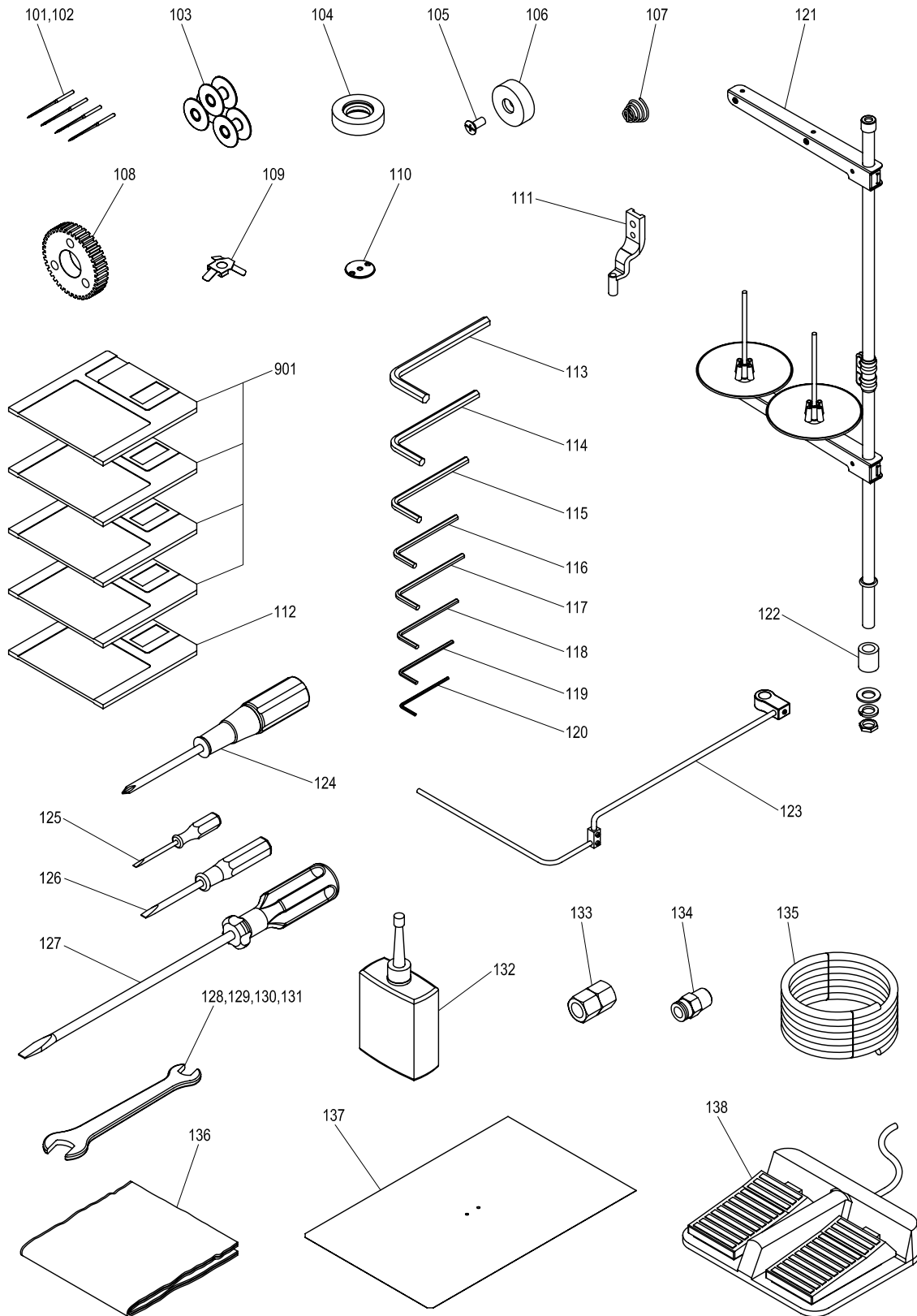

[S]付属品
ACCESSORIES

Fig no.	変更 Mod.	部品コード Parts no.	品 名	Description	数量 Amt. Req.
S 101		MG23C0128	ミンハリ DDX1#25	Needle DDX1#25	4
S 102		MS06A0128	ミンハリ DDX1#26	Needle DDX1#26	4
S 103		MG23C0123	ホビン	Bobbin	3
S 104		MS03A0417	ゴムワ	Tire	1
S 105		M91500010	Pサラネジ M5X12	Screw M5X12	1
S 106	A	MA30A0475	シュウトウシ	Slider	1
S 107		MA30A0245	エンスイハネ	Tension spring	1
S 108		MA30A2722	ヒラハグルマ	Squr gear	1
S 109		MS06A0192	イタハネ	Plate spring	2
S 110		MS06A1101	ハリイタ φ2.8	Needle plate φ2.8	1
S 111		MA30A0256	ナカオサエ φ4	Presser foot φ4	1
S 112		MB60A1990	データロッドディスク	Pattern data F/D	1
S 113		MS05A1976	ロッカクホウレンチ 6	Hexagonal wrench 6	1
S 114		MS05A0976	ロッカクホウレンチ 5	Hexagonal wrench 5	1
S 115		MS01A1976	ロッカクホウレンチ 4	Hexagonal wrench 4	1
S 116		MF90A0976	ロッカクホウレンチ 1/8"	Hexagonal wrench 1/8"	1
S 117		MS02A2976	ロッカクホウレンチ 3	Hexagonal wrench 3	1
S 118		MS02A1976	ロッカクホウレンチ 2.5	Hexagonal wrench 2.5	1
S 119		MS02A0976	ロッカクホウレンチ 2	Hexagonal wrench 2	1
S 120		MS10A0976	ロッカクホウレンチ 1.5	Hexagonal wrench 1.5	1
S 121	A	MF33E0193	イタタテイクミタテ	Cotton stand assy	1
S 122		MA30A0352	イタタテイカラー	Cotton stand collar	1
S 123	A	ME50E0180	イアンナイ	Thread guide	1
S 124		MS05A0608	プラスドライバー	Plus driver	1
S 125		MB02A1608	ドライバー (ショウ)	Screw driver (small)	1
S 126		MB02A0608	ドライバー (チュウ)	Screw driver (middle)	1
S 127		MF00A0608	ドライバー (ダイ)	Screw driver (large)	1
S 128		MS02A0479	スパナ 13-17	Spanner 13-17	1
S 129		MM10A1479	スパナ 10-14	Spanner 10-14	1
S 130		MS10A1976	スパナ 8-9	Spanner 8-9	1
S 131		MS10A2976	スパナ 6-7	Spanner 6-7	1
S 132		MF10A0149	アブラサシ	Oiler with oil	1
S 133		M91010089	ロッカクソケット	Socket	1
S 134		MA30A0571	ワンタッチツギテ	Quick joint	1
S 135		MS06A0567	エアチューブ	Air tube	1
S 136		MA35A0734	ビニルカバー	Polyethylene cover	1
S 137		MA30A0797	ホゴフィルム	Film sheet	2
S 138		M860A0FSW	フットスイッチ	Foot switch	1
S 901		ME20E0990	システムフロッドディスク (4マイ)	System F/D (4discs)	1

T オプションパーツ
OPTION PARTS

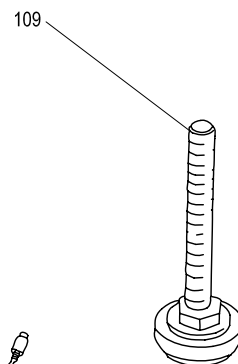
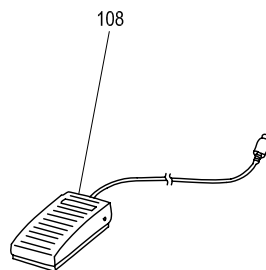
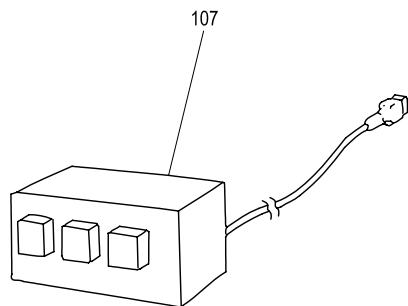
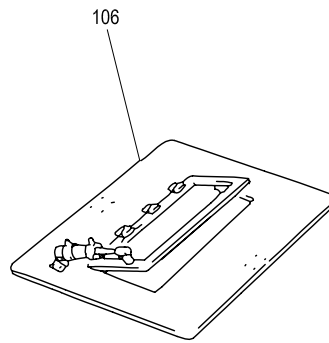
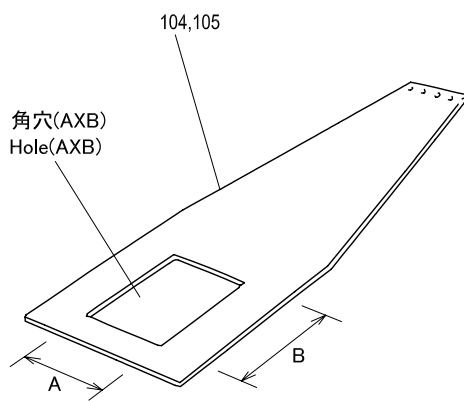
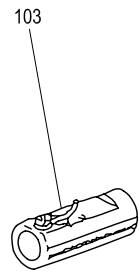
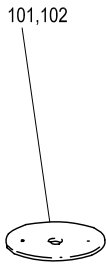

[T]オプションパーツ
OPTION PARTS

Fig no.	変更 Mod.	部品コード Parts no.	品 名	Description	数量 Amt. Req.
T 101		MS06A1101	ハリタ φ2.8	Needle plate φ2.8	1
T 102		MS06A2101	ハリタ φ4.8	Needle plate φ4.8	1
T 103		MS10A0180	イトアンナイ	Thread guide	1
T 104	A	ME30A1272	シタオサエタ (150X300)	Feed plate (150X300)	1
T 105	A	ME30A2272	シタオサエタ (角穴ナシ)	Feed plate (without hole)	1
*T 106		—————	ニダンオサエ (下記参照)	Two-step work holder	1
T 107		M820A0PSW	テモトスイッチ	Hand switch	1
T 108		MB80A0FSW	フットスイッチ	Foot switch	1
T 109		MA30A0166	レベルアジャスタ (長尺)	Adjuster (long)	1

* 二段押えは用途により寸法形状が異なりますから、ご商談の時点で仕様を打合せていただきます。
Two-step work holder of size and shape are different depending on purposes.
Specifications subject finalizing at negotiation.

索引
INDEX-1

部品コード Parts No.	ページ Page	Fig No.	部品コード Parts No.	ページ Page	Fig No.	部品コード Parts No.	ページ Page	Fig No.	部品コード Parts No.	ページ Page	Fig No.
K14M09022805	*** P25	*** N 103	M90901045	*** P23	*** M 106	M91132002	*** P31	*** R 116	M94010017	*** P17	*** J 111
K14M71725402	*** P25	*** N 114	M90901060	*** P11	*** F 120	M91181003	*** P7	*** D 109	M94012017	*** P17	*** J 117
K14M97714201	*** P15	*** H 126	M90903002	*** P13	*** G 112	M91201053	*** P15	*** H 118	M95001017	*** P17	*** J 122
K14MXCKE01P0	*** P25	*** N 104	M90904011	*** P3	*** B 141	M91202050	*** P15	*** H 117	↑	*** P19	*** K 134
M800E2CON	*** P25	*** N 116	M90905002	*** P13	*** G 107	M91203002	*** P9	*** E 102	M95001020	*** P21	*** L 133
M820A0PSW	*** P35	*** T 107	M90906002	*** P3	*** B 119	↑	*** P11	*** F 134	M95002017	*** P21	*** L 107
M860A0FSW	*** P33	*** S 138	M90909003	*** P9	*** E 116	M91207002	*** P5	*** C 127	↑	*** P29	*** Q 102
M90101021	*** P15	*** H 108	M90918002	*** P23	*** M 105	M91210002	*** P11	*** F 133	M95003017	*** P21	*** L 150
M90104021	*** P15	*** H 119	M90971004	*** P19	*** K 131	↑	*** P7	*** D 125	M95004017	*** P19	*** K 138
M90105021	*** P3	*** B 109	M91002053	*** P15	*** H 131	M91213015	*** P11	*** F 108	↑	*** P3	*** B 130
M90106021	*** P15	*** H 130	M91003053	*** P3	*** B 110	M91251002	*** P7	*** D 111	↑	*** P21	*** L 134
M90108062	*** P21	*** L 127	↑	*** P15	*** H 106	M91251015	*** P11	*** F 135	M95004021	*** P21	*** L 104
M90208060	*** P3	*** B 151	M91004067	*** P5	*** C 117	M91382045	*** P21	*** L 124	M95005017	*** P17	*** J 103
M90232060	*** P13	*** G 116	M91005067	*** P5	*** C 114	M91500010	*** P33	*** S 105	↑	*** P27	*** P 111
M90304060	*** P11	*** F 140	M91010089	*** P33	*** S 133	↑	*** P21	*** L 114	↑	*** P21	*** L 155
M90317050	*** P17	*** J 116	M91012050	*** P3	*** B 111	M91502002	*** P11	*** F 121	M95006020	*** P3	*** B 124
M90325060	*** P13	*** G 119	↑	*** P15	*** H 105	M91503052	*** P13	*** G 108	↑	*** P17	*** J 120
M90332065	*** P15	*** H 122	M91013004	*** P5	*** C 105	M91504052	*** P13	*** G 108	↑	*** P7	*** D 131
M90401061	*** P11	*** F 115	M91050020	*** P7	*** D 117	M91506001	*** P11	*** F 117	M95008017	*** P21	*** L 112
M90402063	*** P9	*** E 119	↑	*** P21	*** L 103	↑	*** P7	*** D 140	↑	*** P19	*** K 122
M90406064	*** P7	*** D 135	M91054004	*** P3	*** B 102	M91508001	*** P3	*** B 117	M95008021	*** P21	*** L 148
M90420063	*** P13	*** G 115	↑	*** P19	*** K 129	M91512002	*** P11	*** F 110	M95011021	*** P21	*** L 123
M90421050	*** P17	*** J 110	↑	*** P25	*** N 105	M91513001	*** P9	*** E 114	M95011050	*** P3	*** B 160
↑	*** P13	*** G 125	M91055020	*** P5	*** C 106	M91515002	*** P7	*** D 118	M95016021	*** P21	*** L 105
↑	*** P3	*** B 138	M91056004	*** P25	*** N 106	↑	*** P11	*** F 126	M95020045	*** P31	*** R 137
M90422050	*** P17	*** J 108	M91057020	*** P5	*** C 104	M91517001	*** P7	*** D 104	M95022045	*** P21	*** L 130
↑	*** P13	*** G 110	M91058004	*** P31	*** R 120	M91602002	*** P13	*** G 123	M95030021	*** P19	*** K 136
M90424053	*** P13	*** G 111	M91064004	*** P31	*** R 103	↑	*** P9	*** E 115	M95031021	*** P3	*** B 132
↑	*** P3	*** B 139	M91066004	*** P27	*** P 103	M91602046	*** P5	*** C 119	M95054095	*** P19	*** K 127
M90439037	*** P25	*** N 117	M91071004	*** P19	*** K 137	M91603046	*** P3	*** B 136	M95055095	*** P19	*** K 119
M90504053	*** P21	*** L 125	↑	*** P17	*** J 101	M91650020	*** P9	*** E 134	M96001001	*** P19	*** K 105
M90506064	*** P17	*** J 123	↑	*** P31	*** R 106	↑	*** P15	*** H 128	M96002001	*** P19	*** K 114
M90510050	*** P13	*** G 120	M91073004	*** P25	*** N 112	M91651020	*** P15	*** H 112	M96002017	*** P3	*** B 127
M90511050	*** P27	*** P 110	↑	*** P19	*** K 142	M91802006	*** P7	*** D 120	M96003020	*** P9	*** E 113
↑	*** P21	*** L 108	M91102033	*** P11	*** F 153	M91815015	*** P11	*** F 105	M96003031	*** P15	*** H 107
↑	*** P19	*** K 123	M91104045	*** P11	*** F 130	M91910080	*** P3	*** B 114	M96004017	*** P9	*** E 126
M90511063	*** P7	*** D 124	M91106003	*** P3	*** B 145	M92001001	*** P7	*** D 126	M96004031	*** P15	*** H 115
M90512050	*** P19	*** K 139	M91108001	*** P7	*** D 101	M92002050	*** P31	*** R 136	M96010017	*** P19	*** K 121
↑	*** P17	*** J 121	M91108002	*** P9	*** E 124	M92051003	*** P9	*** E 125	M97014060	*** P21	*** L 106
M90519063	*** P11	*** F 144	↑	*** P11	*** F 123	M92075045	*** P31	*** R 113	M97015060	*** P21	*** L 126
M90601002	*** P7	*** D 107	M91109004	*** P3	*** B 104	↑	*** P21	*** L 143	M98001015	*** P21	*** L 137
M90604065	*** P19	*** K 103	M91110002	*** P3	*** B 107	M92402045	*** P11	*** F 103	M98001033	*** P21	*** L 136
M90605010	*** P13	*** G 103	↑	*** P13	*** G 114	M92404035	*** P11	*** F 104	M98001037	*** P21	*** L 118
M90631050	*** P19	*** K 120	↑	*** P11	*** F 101	M93011050	*** P15	*** H 132	M98003017	*** P21	*** L 131
M90632050	*** P9	*** E 127	↑	*** P7	*** D 122	M93012050	*** P21	*** L 140	↑	*** P11	*** F 149
M90709063	*** P9	*** E 118	↑	*** P11	*** F 139	M93013050	*** P21	*** L 145	M98003020	*** P9	*** E 130
M90740080	*** P23	*** M 111	↑	*** P23	*** M 118	M94001017	*** P17	*** J 126	M98020022	*** P31	*** R 110
M90802033	*** P11	*** F 154	M91111001	*** P11	*** F 132	↑	*** P25	*** N 102	M98081021	*** P15	*** H 116
M90803053	*** P21	*** L 142	M91113002	*** P11	*** F 152	M94003035	*** P11	*** F 127	M99006063	*** P5	*** C 107
↑	*** P31	*** R 112	↑	*** P3	*** B 113	M94005017	*** P17	*** J 115	MA20A0194	*** P5	*** C 110
M90803060	*** P21	*** L 132	M91113004	*** P23	*** M 101	M94006017	*** P17	*** J 112	MA20A1950	*** P5	*** C 103
M90806002	*** P3	*** B 150	M91116002	*** P11	*** F 142	M94007017	*** P17	*** J 107	MA20A7571	*** P27	*** P 108
M90823050	*** P31	*** R 111	M91118002	*** P23	*** M 112	M94007045	*** P11	*** F 128	MA20A8571	*** P27	*** P 105
M90825050	*** P21	*** L 141	↑	*** P13	*** G 121	M94009021	*** P3	*** B 140	MA30A0166	*** P35	*** T 109
M90859004	*** P17	*** J 133	M91119002	*** P7	*** D 137	M94010017	*** P5	*** C 111	MA30A0230	*** P7	*** D 129

索引
INDEX-2

部品コード Parts No.	ページ Page	Fig No.	部品コード Parts No.	ページ Page	Fig No.	部品コード Parts No.	ページ Page	Fig No.	部品コード Parts No.	ページ Page	Fig No.
MA30A0245	*** P33	*** S 107	MA30A0922	*** P17	*** J 130	MA30A4454	*** P21	*** L 111	MB30E0599	*** P27	*** P 102
MA30A0256	*** P11	*** F 151	MA30A0957	*** P17	*** J 113	MA30A4456	*** P21	*** L 901	MB30E0691	*** P21	*** L 153
↑	*** P33	*** S 111	MA30A0964	*** P29	*** Q 106	MA30A4523	*** P15	*** H 136	MB30E0963	*** P27	*** P 104
MA30A0257	*** P31	*** R 123	MA30A1180	*** P7	*** D 114	MA30A4682	*** P15	*** H 135	MB30E1691	*** P21	*** L 152
MA30A0262	*** P11	*** F 137	MA30A1230	*** P15	*** H 109	MA30A4750	*** P21	*** L 120	MB35A0390	*** P19	*** K 113
MA30A0273	*** P21	*** L 113	MA30A1257	*** P31	*** R 125	MA30A4780	*** P3	*** B 123	MB35A7601	*** P25	*** N 121
MA30A0339	*** P31	*** R 135	MA30A1273	*** P21	*** L 121	MA30A5456	*** P21	*** L 117	MB45A0767	*** P19	*** K 109
MA30A0350	*** P5	*** C 116	MA30A1339	*** P31	*** R 114	MA30A5571	*** P29	*** Q 104	MB50A0626	*** P11	*** F 150
MA30A0352	*** P33	*** S 122	MA30A1352	*** P7	*** D 139	MA30A5750	*** P21	*** L 119	MB50A1972	*** P31	*** R 139
MA30A0359	*** P31	*** R 117	MA30A1359	*** P31	*** R 129	MA30A5780	*** P15	*** H 124	MB50A3339	*** P25	*** N 111
MA30A0361	*** P31	*** R 132	MA30A1422	*** P13	*** G 122	MA30A6339	*** P3	*** B 108	MB60A0366	*** P25	*** N 113
MA30A0364	*** P19	*** K 111	MA30A1434	*** P3	*** B 126	MA30A6456	*** P21	*** L 110	MB60A0915	*** P25	*** N 108
MA30A0422	*** P27	*** P 109	MA30A1454	*** P19	*** K 116	MA30A6750	*** P21	*** L 116	MB60A1990	*** P33	*** S 112
↑	*** P11	*** F 148	MA30A1456	*** P15	*** H 103	MA30A7339	*** P15	*** H 114	MB60A2352	*** P25	*** N 115
MA30A0426	*** P15	*** H 104	MA30A1458	*** P31	*** R 127	↑	*** P21	*** L 149	MB60A5601	*** P25	*** N 118
MA30A0434	*** P3	*** B 105	MA30A1476	*** P31	*** R 130	MA30A7920	*** P17	*** J 134	MB60A5780	*** P25	*** N 119
MA30A0450	*** P15	*** H 133	MA30A1477	*** P17	*** J 137	MA30A8920	*** P17	*** J 114	MB60A6780	*** P25	*** N 120
MA30A0454	*** P19	*** K 107	MA30A1567	*** P29	*** Q 105	MA30E0257	*** P21	*** L 903	MB60E3339	*** P25	*** N 902
MA30A0456	*** P9	*** E 132	MA30A1682	*** P15	*** H 111	MA30E0272	*** P21	*** L 904	MB62A0767	*** P19	*** K 117
MA30A0457	*** P21	*** L 115	MA30A1722	*** P9	*** E 112	MA30E0603	*** P31	*** R 107	MB80A0FSW	*** P35	*** T 108
MA30A0458	*** P31	*** R 122	MA30A1743	*** P15	*** H 110	MA30E0750	*** P5	*** C 108	ME03A0270	*** P25	*** N 110
MA30A0474	*** P5	*** C 128	MA30A1747	*** P31	*** R 131	MA30E0802	*** P25	*** N 101	ME20E0990	*** P33	*** S 901
MA30A0475	*** P33	*** S 106	MA30A1750	*** P9	*** E 129	MA30E1191	*** P5	*** C 102	ME25A0416	*** P7	*** D 141
MA30A0476	*** P31	*** R 118	MA30A1780	*** P31	*** R 126	MA30E1339	*** P31	*** R 105	ME25A0682	*** P7	*** D 136
MA30A0483	*** P21	*** L 135	MA30A1809	*** P29	*** Q 103	MA30E2339	*** P31	*** R 101	ME25A1833	*** P7	*** D 132
MA30A0523	*** P19	*** K 104	MA30A1921	*** P3	*** B 120	MA30E3339	*** P31	*** R 104	ME30A0272	*** P21	*** L 151
MA30A0571	*** P33	*** S 134	MA30A1922	*** P17	*** J 138	MA30E4339	*** P31	*** R 102	ME30A0339	*** P27	*** P 101
MA30A0584	*** P3	*** B 103	MA30A1957	*** P17	*** J 119	MA35A0166	*** P31	*** R 138	ME30A0407	*** P17	*** J 135
MA30A0595	*** P31	*** R 109	MA30A2257	*** P3	*** B 131	MA35A0734	*** P33	*** S 136	ME30A0408	*** P19	*** K 128
MA30A0600	*** P5	*** C 112	MA30A2339	*** P31	*** R 133	MA35A0781	*** P17	*** J 128	ME30A0434	*** P21	*** L 902
MA30A0601	*** P31	*** R 128	MA30A2352	*** P15	*** H 123	MA35A1758	*** P19	*** K 133	ME30A0454	*** P7	*** D 134
MA30A0602	*** P31	*** R 121	MA30A2364	*** P15	*** H 101	MA35A2572	*** P7	*** D 133	ME30A0476	*** P19	*** K 141
MA30A0660	*** P7	*** D 115	MA30A2434	*** P11	*** F 147	MA35A6758	*** P19	*** K 135	ME30A0477	*** P17	*** J 118
MA30A0664	*** P7	*** D 113	MA30A2454	*** P3	*** B 122	MA36A6780	*** P15	*** H 134	ME30A0484	*** P19	*** K 130
MA30A0682	*** P7	*** D 130	MA30A2456	*** P15	*** H 113	MA70A0838	*** P13	*** G 109	ME30A0508	*** P25	*** N 107
MA30A0692	*** P17	*** J 106	MA30A2477	*** P17	*** J 129	MB02A0608	*** P33	*** S 126	ME30A0571	*** P27	*** P 106
MA30A0700	*** P21	*** L 128	MA30A2523	*** P19	*** K 110	MB02A1608	*** P33	*** S 125	ME30A0601	*** P17	*** J 104
MA30A0708	*** P21	*** L 129	MA30A2530	*** P5	*** C 129	MB30A0160	*** P3	*** B 146	ME30A0780	*** P17	*** J 105
MA30A0716	*** P21	*** L 147	MA30A2603	*** P5	*** C 113	MB30A0259	*** P11	*** F 129	ME30A0920	*** P17	*** J 124
MA30A0725	*** P11	*** F 145	MA30A2682	*** P15	*** H 120	MB30A0339	*** P3	*** B 101	ME30A1272	*** P35	*** T 104
MA30A0747	*** P31	*** R 115	MA30A2722	*** P9	*** E 128	MB30A0364	*** P19	*** K 118	ME30A1477	*** P17	*** J 139
MA30A0751	*** P19	*** K 125	↑	*** P33	*** S 108	MB30A0390	*** P19	*** K 108	ME30A1484	*** P19	*** K 140
MA30A0755	*** P31	*** R 119	MA30A2750	*** P21	*** L 109	MB30A0434	*** P13	*** G 901	ME30A1571	*** P13	*** G 126
MA30A0757	*** P29	*** Q 107	MA30A2758	*** P3	*** B 121	MB30A0523	*** P19	*** K 112	ME30A1780	*** P17	*** J 127
MA30A0758	*** P19	*** K 132	MA30A2767	*** P9	*** E 133	MB30A0603	*** P19	*** K 126	ME30A2272	*** P35	*** T 105
MA30A0767	*** P19	*** K 101	MA30A3257	*** P21	*** L 154	MB30A0750	*** P19	*** K 115	ME30A2477	*** P17	*** J 140
MA30A0777	*** P15	*** H 127	MA30A3339	*** P31	*** R 134	MB30A0767	*** P19	*** K 106	ME30E0270	*** P25	*** N 901
MA30A0778	*** P17	*** J 132	MA30A3352	*** P21	*** L 102	MB30A0830	*** P3	*** B 115	ME30E0331	*** P7	*** D 902
MA30A0780	*** P31	*** R 124	MA30A3454	*** P9	*** E 131	MB30A0963	*** P27	*** P 107	ME50E0180	*** P33	*** S 123
MA30A0785	*** P3	*** B 128	MA30A3456	*** P15	*** H 121	MB30A1407	*** P17	*** J 102	MF00A0608	*** P33	*** S 127
MA30A0796	*** P3	*** B 129	MA30A3523	*** P15	*** H 125	MB30A1601	*** P17	*** J 136	MF10A0149	*** P33	*** S 132
MA30A0797	*** P33	*** S 137	MA30A3603	*** P21	*** L 138	MB30A2601	*** P25	*** N 109	MF10A0555	*** P5	*** C 122
↑	*** P31	*** R 108	MA30A3682	*** P15	*** H 129	MB30A3601	*** P25	*** N 122	MF10A0689	*** P23	*** M 119
MA30A0809	*** P29	*** Q 101	MA30A3750	*** P21	*** L 101	MB30A5601	*** P3	*** B 144	MF10A0731	*** P23	*** M 108
MA30A0921	*** P17	*** J 109	MA30A4434	*** P21	*** L 146	MB30E0476	*** P17	*** J 131	MF10A2245	*** P11	*** F 156

索引
INDEX-3

部品コード Parts No.	ページ Page	Fig No.	部品コード Parts No.	ページ Page	Fig No.	部品コード Parts No.	ページ Page	Fig No.	部品コード Parts No.	ページ Page	Fig No.
MF10E2148	*** P23	*** M 116	MG23C1910	*** P11	*** F 106	MS06A0472	*** P13	*** G 101			
MF33E0193	*** P33	*** S 121	MG23C2555	*** P3	*** B 158	MS06A0473	*** P5	*** C 126			
MF36A1180	*** P3	*** B 106	MG23C4740	*** P3	*** B 157	MS06A0530	*** P13	*** G 117			
MF40A0259	*** P11	*** F 107	MG23C6740	*** P9	*** E 107	MS06A0567	*** P33	*** S 135			
MF90A0976	*** P33	*** S 116	MG23E0258	*** P9	*** E 120	MS06A0602	*** P13	*** G 124			
MG23A0731	*** P23	*** M 120	MG23E0384	*** P11	*** F 124	MS06A0740	*** P23	*** M 103			
MG23C0123	*** P9	*** E 105	MG23E0582	*** P7	*** D 901	MS06A0840	*** P13	*** G 104			
↑	*** P33	*** S 103	MG23E0616	*** P9	*** E 901	MS06A1101	*** P35	*** T 101			
↑	*** P5	*** C 101	MG23E1582	*** P7	*** D 105	↑	*** P33	*** S 110			
MG23C0128	*** P7	*** D 116	MG30B0285	*** P11	*** F 119	MS06A2101	*** P35	*** T 102			
↑	*** P33	*** S 101	MG43A0181	*** P3	*** B 143	MS06A3601	*** P3	*** B 142			
MG23C0187	*** P3	*** B 154	MG43A1181	*** P3	*** B 137	MS06B0838	*** P13	*** G 105			
MG23C0192	*** P9	*** E 123	MG75A1476	*** P5	*** C 125	MS06E0391	*** P13	*** G 902			
MG23C0210	*** P3	*** B 902	MM10A1479	*** P33	*** S 129	MS06E0460	*** P11	*** F 901			
MG23C0216	*** P3	*** B 116	MM11A0245	*** P5	*** C 121	MS06E0720	*** P11	*** F 143			
MG23C0226	*** P11	*** F 112	MM11A0702	*** P5	*** C 120	MS06E1120	*** P9	*** E 103			
MG23C0232	*** P7	*** D 128	MN10A1691	*** P23	*** M 114	MS10A0180	*** P35	*** T 103			
MG23C0245	*** P3	*** B 135	MN10A3742	*** P23	*** M 113	MS10A0976	*** P33	*** S 120			
MG23C0257	*** P9	*** E 121	MN10A4742	*** P23	*** M 115	MS10A1976	*** P33	*** S 130			
MG23C0258	*** P9	*** E 117	MN70E0148	*** P23	*** M 104	MS10A2976	*** P33	*** S 131			
MG23C0263	*** P11	*** F 141	↑	*** P23	*** M 117	MS13A5454	*** P19	*** K 102			
MG23C0265	*** P11	*** F 131	MN80A0180	*** P3	*** B 112	MS14A0553	*** P5	*** C 123			
MG23C0325	*** P7	*** D 121	MP00B0740	*** P7	*** D 127	MS14A0572	*** P5	*** C 118			
MG23C0383	*** P7	*** D 119	MP40A3740	*** P7	*** D 103	MS14A1180	*** P5	*** C 124			
MG23C0400	*** P23	*** M 109	MQ40A1497	*** P3	*** B 125	MS14A1454	*** P5	*** C 115			
MG23C0450	*** P9	*** E 108	MQ50A0181	*** P3	*** B 118	MS14E0180	*** P5	*** C 901			
MG23C0452	*** P9	*** E 111	MS01A1976	*** P33	*** S 115	MV11A0134	*** P23	*** M 102			
MG23C0475	*** P11	*** F 136	MS02A0479	*** P33	*** S 128						
MG23C0553	*** P3	*** B 133	MS02A0976	*** P33	*** S 119						
MG23C0555	*** P3	*** B 134	MS02A1976	*** P33	*** S 118						
MG23C0556	*** P3	*** B 161	MS02A2456	*** P19	*** K 124						
MG23C0557	*** P3	*** B 153	MS02A2976	*** P33	*** S 117						
MG23C0585	*** P7	*** D 108	MS03A0417	*** P33	*** S 104						
MG23C0587	*** P7	*** D 106	↑	*** P5	*** C 109						
MG23C0661	*** P7	*** D 110	MS05A0608	*** P33	*** S 124						
MG23C0662	*** P7	*** D 123	MS05A0750	*** P21	*** L 144						
MG23C0665	*** P7	*** D 112	MS05A0976	*** P33	*** S 114						
MG23C0689	*** P23	*** M 107	MS05A1976	*** P33	*** S 113						
MG23C0750	*** P3	*** B 155	MS05A3454	*** P21	*** L 122						
MG23C0751	*** P11	*** F 138	MS05A4454	*** P21	*** L 139						
MG23C0760	*** P11	*** F 125	MS06A0101	*** P13	*** G 102						
MG23C0763	*** P11	*** F 114	MS06A0128	*** P33	*** S 102						
MG23C0781	*** P9	*** E 122	MS06A0155	*** P13	*** G 106						
MG23C1157	*** P11	*** F 109	MS06A0192	*** P9	*** E 104						
MG23C1210	*** P3	*** B 901	↑	*** P33	*** S 109						
MG23C1233	*** P7	*** D 138	MS06A0220	*** P11	*** F 155						
MG23C1261	*** P11	*** F 102	MS06A0226	*** P11	*** F 111						
MG23C1277	*** P11	*** F 122	MS06A0229	*** P9	*** E 101						
MG23C1352	*** P9	*** E 110	MS06A0250	*** P23	*** M 110						
MG23C1453	*** P9	*** E 109	MS06A0276	*** P11	*** F 116						
MG23C1553	*** P3	*** B 156	MS06A0307	*** P13	*** G 113						
MG23C1555	*** P3	*** B 159	MS06A0352	*** P11	*** F 113						
MG23C1557	*** P3	*** B 162	MS06A0391	*** P13	*** G 118						
MG23C1663	*** P7	*** D 102	MS06A0454	*** P11	*** F 146						
MG23C1750	*** P3	*** B 152	MS06A0460	*** P11	*** F 118						

MEMO

A series of horizontal dashed lines for writing.

MEMO

A series of horizontal dashed lines for writing.



お問い合わせは下記どうぞ

F A システム事業本部 機器計画部 駆動機器グループ 〒100-8310 東京都千代田区丸の内 2-7-3 (東京ビル)
代表電話番号 (03)3218-6631 代表 F A X 番号 (03)3218-6823



FACTORY AUTOMATION SYSTEM GROUP

2-7-3, Marunouchi Chiyoda-ku Tokyo 100-8310, Japan

Fax : +81-3-3218-6821